

## DUSTOMAT 4-10

(09.730)

Mains voltage (V)	400	Filter surface (m <sup>2</sup> )	10
Nominal current (kW)	2.2	Filter quantity (pc)	2
Mains frequency (Hz)	50	Cleaning type	Jet pulse
Circuit breaker (A)	C16	Collection volume (liter)	38
Max. volume flow (m <sup>3</sup> /h)	2,000	Dimensions (L x W x H) (mm)	1,470 x 920 x 1,440
Max. neg. pressure (Pa)	2,600	Weight (kg)	approx. 230
Intake opening (mm)	160	Comp. air consumption* (l/impuls)	approx. 19
Sound pressure level LpA(dBA)	68	Comp. air connection (bar)	4 – 6

\*at 4 bar with valve opening 0,12 sec

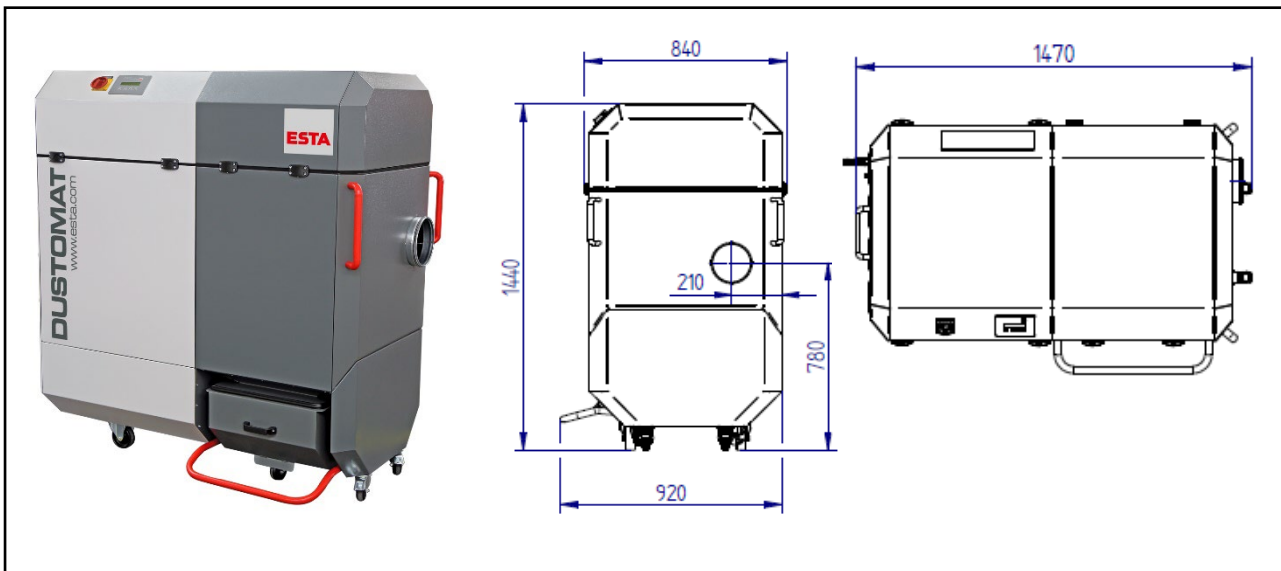

## ESTA PLUS

### Application range:

- Dust extraction at individual or multiple workstations or machines in industrial plants or smaller shops
- Pourable dust and dry chips

### Your benefits at a glance

- All-purpose for dust and shavings
- Compact and powerful
- Low operating costs
- Convenient dust disposal
- Extremely quiet operation
- Test certificate for special application
- New innovative cabinet design, therefore providing a small footprint

### Characteristics:

- Pulse-jet filter cleaning system
- Cleanable long life cartridge filters (dust classification M)
- Integrated impact separator
- Mobile dust collection drawer for easy disposal
- Total capacity dust collection bin ~90 l
- Mobile on rolls

### Custom design/optional:

- stationary
- ATEX-Modification
- with Backup filter cassette (dust class H)
- with floating contact

State of the art: 09730-51-02 Subject to change without notice! For remaining questions, please do not hesitate to contact us.

ESTA Apparatebau GmbH & Co. KG  
Gotenstraße 2 – 6  
89250 Senden / GERMANY

Phone +49 7307 804-0  
Fax +49 7307 804-500  
E-Mail info@esta.com

[www.esta.com](http://www.esta.com)