

DUSTOMAT 4-24

(09.760)

Mains voltage (V)	400	Filter surface (m ²)	24
Nominal power (kW)	4.0	Filter quantity (pc)	2
Mains frequency (Hz)	50	Cleaning type	Jet pulse
Circuit breaker (A)	C16	Collection volume (liter)	38
Max. volume flow (m ³ /h)	3,300	Dimensions (L x W x H) (mm)	1,670 x 920 x 1,640
Max. neg. pressure (Pa)	3,600	Weight (kg)	280
Intake opening (mm)	200	Comp. air consumption* (l/impuls)	approx. 19
Sound pressure level LpA(dBA)	72	Comp. air connection (bar)	4 – 6

*at 4 bar with valve opening 0,12 sec

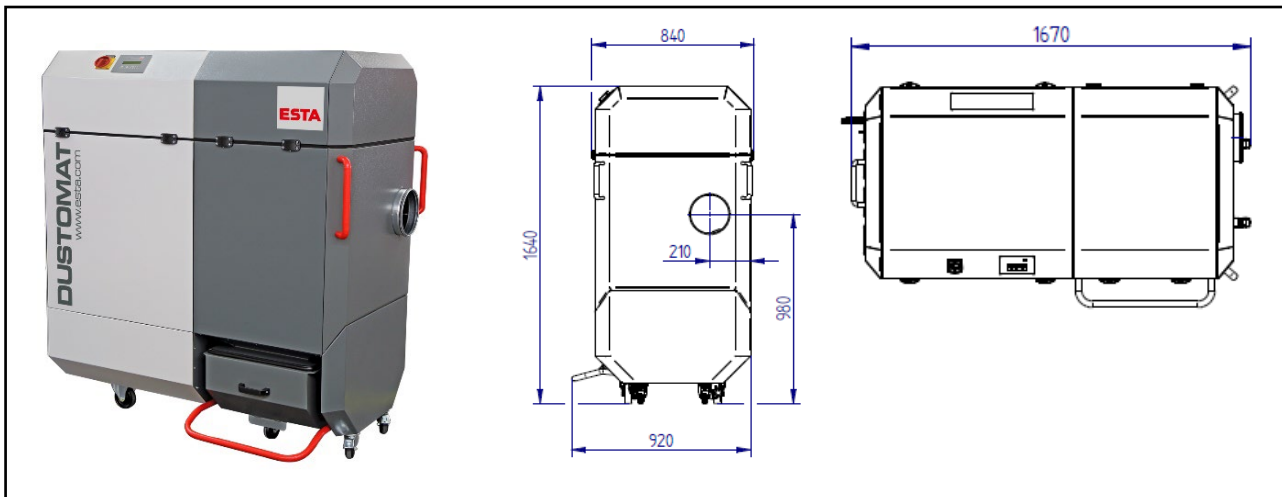

ESTA PLUS

Application range:

- Dust extraction at individual or multiple workstations or machines in industrial plants or smaller shops
- Pourable dust and dry chips

Your benefits at a glance

- All-purpose for dust and shavings
- Compact and powerful
- Low operating costs
- Convenient dust disposal
- Extremely quiet operation
- Test certificate for special application
- New innovative cabinet design, therefore providing a small footprint

Characteristics:

- Pulse-jet filter cleaning system
- Cleanable long life cartridge filters (dust classification M)
- Integrated impact separator
- Mobile dust collection drawer for easy disposal
- Total capacity dust collection bin ~90 l
- Mobile on rolls

Custom design/optional:

- stationary
- ATEX-Modification
- with Backup filter cassette (dust class H)
- with floating contact

State of the art: 09760-51-03 Subject to change without notice! For remaining questions, please do not hesitate to contact us.

ESTA Apparatebau GmbH & Co. KG
Gotenstraße 2 – 6
89250 Senden / GERMANY

Phone +49 7307 804-0
Fax +49 7307 804-500
E-Mail info@esta.com

www.esta.com