









# — PRODUCT CATALOGUE —



2023

# Legend









## Types of filter cleaning

	Manual brush cleaning	The cartridge filter's folds are gently tapped by brushes. This effectively loosens especially coarse and free-flowing dusts. The brush axle turns in two directions in the middle of the cartridge (on the raw gas side). This cleaning comes in manual, motorized and automatic motorized versions.
	Manual rotation filter cleaning	A compressed air connection on the hand-operated rotation nozzle ensures that the filter lamellas are blown uniformly clean.
	Manual standard filter cleaning	Fast, effective filter cleaning with a hand-held compressed air pistol blows the filter lamellas clean inside and out. Smoke particles come loose from the filter material and fall into the filter housing's dust collection channel.
	Manual bag filter cleaning	Filter bags fastened to a frame are freed of built-up shavings and dust particles using a hand crank. With an eccentric tappet, the crank shifts the frame by vibration, which shakes off the dirt and drops it into a collection container located below.
	Fully automatic filter cleaning	In automatic cleaning, the filter is cleared after the fan stops. On devices with an IFA test certificate, an acoustic signal indicates the need for filter cleaning.
	Pulse-jet filter cleaning	Pulse-jet cleaning clears the filter cartridges from the inside out (clean gas side). This loosens dust stuck to the exterior of the cartridges, and it falls into the collection container. The filter cartridges are automatically cleaned individually. Pulse-jet cleaning allows filter cleaning during and after suction operation with no need to shut off the extractor.

## Installation types

	Stationary	Stationary dust extractors are installed next to the processing machine or at a central location in production halls.
	Mobile	Mobile dust extractors can be installed for single-location or central extraction in production halls.
	Portable	With their compact dimensions, these dust extractors can be transported quickly and easily.

## Certificates and Seal

	Dust class M Transmittance < 0.1%. Class M dusts are considered "moderately" toxic.		Tested Safety Confirmation by an independent body that the product meets health and safety requirements.
	Dust class H Transmittance < 0.005%. Dusts of this class are considered "highly" toxic.		BG test characters The BG testing and certification bodies awarded the BG test character (formerly BG characters). This certifies that the product complies with the relevant requirements of health and safety.
	Zone 22 The area in which an explosive atmosphere is never or only briefly present during normal operation.		Product Specific Approvals For products with BG test characters with character added a special aspect was examined
	ATEX-compliant devices (ATmosphere EXplosive) for use in explosive areas.		Special guidelines apply when welding stainless steel. Depending on how high the chromium/nickel content of the stainless steel is, devices with an IFA W3 test certificate are needed if air is recirculated.



## Dear Customers and Friends of ESTA,



**Philipp Raunitschke**  
 Managing Director  
 ESTA Apparatebau GmbH & Co. KG

Clean air is a basic need of every human being. In the working environment, it not only ensures the long-term health of employees, but also increases productivity. For over 50 years, ESTA's motivated team of **#airimprovers** has been guaranteeing clean air and clean workplaces around the world. But for us, this is more than just an empty promise! External certificates, such as the quality management standard ISO 9001:2015 and the environmental management standard ISO 14001:2015, prove this! ESTA is thus setting a really strong example when it comes to the environment and sustainability.

Our new **DUSTOMAT DRY** welding fume filters are also energy-efficient and sustainable. They are characterised above all by their modular, resource-saving product architecture and the many configuration options for users. The compact devices effectively and efficiently extract the dust and welding fumes generated when processing metal or plastic. All the information can be found on **pages 14 and 43**.

In addition, we have expanded the **DUSTOMAT HYDRO** series with two new, high-performance variants: The wet filter systems for the extraction of aluminium dust or applications with flying sparks are now available with significantly larger air volume flows of 6,000 m<sup>3</sup>/h and 10,000 m<sup>3</sup>/h of air. With the new performance classes, entire production areas, i. e. several extraction points at the same time, can be covered with just one extraction system. More details on **page 20**.

We would be happy to advise you by telephone on 07307/804-0, or visit our website at **www.esta.com**.

Take advantage of our expertise!

Yours

Philipp Raunitschke



- Dust Extractors
- High Vacuum Extraction Units
- Welding Fume Filters
- Oil Mist Separators
- Carbon Filters/ Air Purifier
- Downdraft Tables
- Extraction Fans
- Extraction Arms
- Filter Towers
- Central Extraction Systems
- Pipe Systems
- About us
- Interesting Information

# Table of Contents

	Page		Page
Your specialist for extraction technology .....	3	<b>Extraction Fans</b>	
<b>Dust Extractors</b>		Introduction and Product Overview .....	60
Equipment overview by pollutants .....	5	Extraction Fans RG-100 to RG-800 .....	61
Introduction and Product Overview .....	6	Extraction Unit RG with Extraction Arm .....	62
Mini Dust Collectors TK, TK-2.2, OM .....	9	RG with Ball-Joint Extraction Arm .....	63
Mobile Dust Extractors DUSTOMAT S-Series .....	11	Mobile Extraction Unit RG with Dust Filter Bag .....	64
Mobile Dust Extractors DUSTOMAT-10 and -16 M .....	12	<b>Extraction Arms</b>	
Mobile Dust Extractors DUSTOMAT DRY <b>NEW</b> .....	14	Introduction and Product Overview .....	66
High Vacuum Power Dust Extractor DUSTOVAC .....	16	Extraction Arms with Flanged Hood .....	67
Compact Dust Extractor ESTMAC D .....	17	Extraction Arms with Efficiency Hood .....	68
Compact Dust Extractor MOBEX P .....	18	Extraction Arms with Square Hood .....	69
Wet Separators DUSTOMAT HYDRO <b>NEW</b> .....	20	Ball-Joint Extraction Arm .....	70
Wet Separators NA 1.1 / NA-2.2SK .....	22	Laboratory Extraction Arm 50 D .....	71
Modular Extractor DUSTMAC P .....	23	<b>FILTER Towers</b>	
Modular Extractor DUSTMAC S .....	24	FILTOWER .....	73
Cyclonic Pre-Separator ZA .....	25	<b>Central Extraction Systems</b>	
<b>High Vacuum Extraction Units</b>		Introduction and Product Overview .....	76
Equipment overview by pollutants .....	27	Switch cabinets for every requirement .....	77
Introduction and Product Overview .....	28	Side Channel Blowers .....	78
High Vacuum Extraction Units		High and Medium Pressure Fans .....	79
EUROSOG, DUROSOG, WHISPERSOG .....	29	Rotary Piston Blowers .....	80
Central Vacuum Cleaner CENTRASOG CVS 2.0 .....	34	Cyclonic Filtration Units .....	81
Wet and Dry Vacuum MULTISOG .....	35	Modular Extractors DUSTMAC .....	82
Pre-Separator Systems for Industrial Vacuum Cleaners .....	36	Modular Welding Fume Filter System WELDEX .....	85
<b>Welding Fume Filters</b>		Hall ventilation systems .....	87
Introduction and Product Overview .....	38	Extraction hoods .....	89
Mobile Welding Fume Filters SRF K .....	39	Soundproofed Cabins .....	90
Portable Welding Fume Filters SRF T .....	42	References .....	92
Welding Fume Filters DUSTOMAT DRY <b>NEW</b> .....	43	<b>Pipe Systems</b>	
Stationary Welding Fume Filters MOBEX F .....	44	Introduction and Product Overview .....	105
Modular Welding Fume Filtrating Systems DUSTMAC F .....	46	Spiral Seam Pipes and Formed Parts .....	106
<b>Oil Mist Separators</b>		Longitudinally welded pipes .....	107
Oil Mist Separators 400 through 3000 .....	48	Steel Pipes and Formed Parts .....	108
<b>Carbon Filter / Air Purifier</b>		<b>About us</b>	
Odour filter ActiveBox® .....	51	What sets us apart .....	109
Room Air Cleaning System TowerBox® .....	52	Energy-efficient extraction technology .....	112
<b>Downdraft Tables</b>		Smart extraction technology .....	113
Downdraft Table TableBox® Air .....	54	Quality from our own production .....	114
Downdraft Table TableBox® Active .....	54	Innovation & Know-how .....	115
Welding/Grinding Downdraft Tables A .....	55	Clean the air – save the ocean .....	116
360°-Suction Table .....	57	Clean the air – plant a tree .....	117
Plasma-cutting Table .....	58	Original Equipment Manufacturer/OEM .....	118
		<b>Interesting information</b>	
		Guidelines and regulations .....	119
		What You Should Know About Dust .....	120
		Fire protection and ATEX .....	122

Sound pressure level ratings according to DIN EN ISO 3744  
We reserve the right to make technical changes

You may already know?

**ESTA is the acronym for “Elektro-Staub-Absauggeräte” (Electric Dust Extraction Equipment).**

For over 50 years, we have offered a broad spectrum of innovative products and custom solutions in the field of extraction technology.

### The product range covers

- » Mobile Dust Extractors
- » Fixed Extraction Systems
- » High Vacuum Extraction Units
- » Welding Fume Filter
- » Air Purifier
- » Oil Mist Separators
- » Odor Filters
- » Extraction Tables/Fans
- » Extraction Arms
- » Central Extraction Systems
- » Filter Towers
- » Pipe Systems
- » Accessories

Every application has its own requirements. The quality of our products and consultation is based on decades of experience. Get all the benefits of ESTA 360° service:

- » Over 50 years of expertise
- » An innovation leader engaged in continuous development
- » Advice and planning from the best-trained sales staff
- » Short delivery times
- » Trouble-free device installation by our production staff and installation team
- » Comprehensive support throughout product life
- » Own switch cabinet construction
- » Large high-bay storage

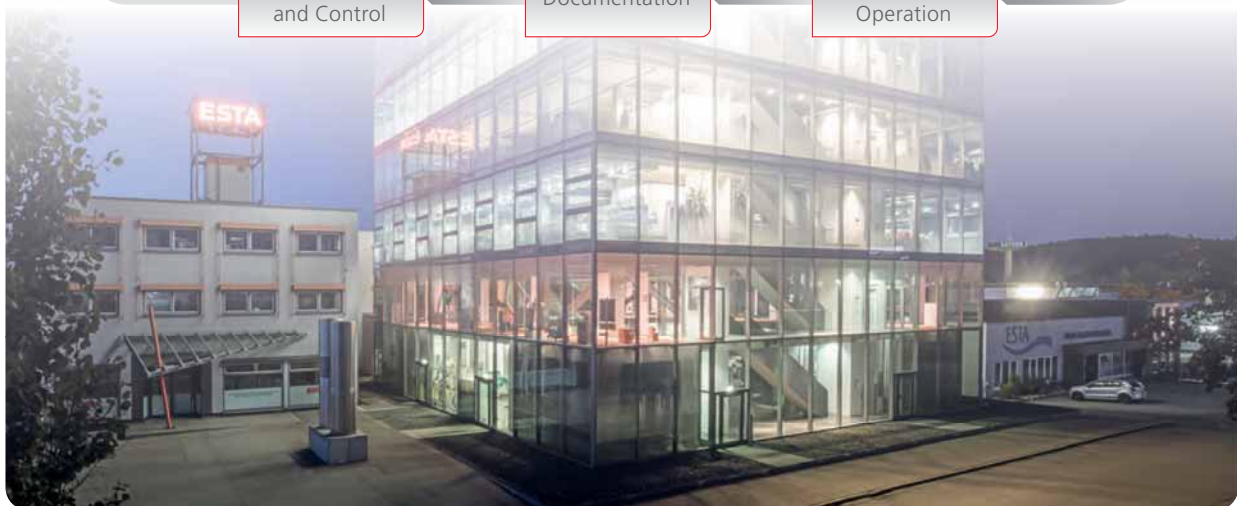
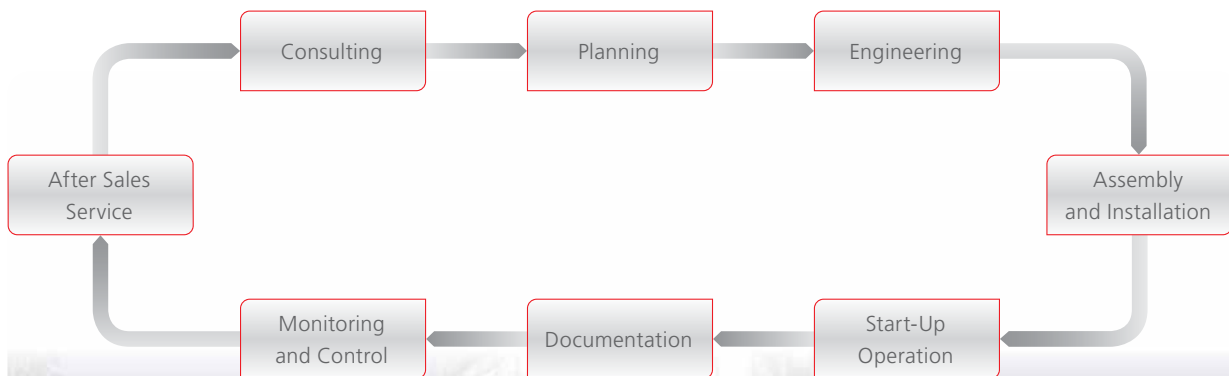

# Dust Extractors

For ultimate flexibility in extracting and filtering dust laden air

TK/TK-2.2

OM

DUSTOMAT S

DUSTOMAT-10/16 M

DUSTOMAT DRY

DUSTOVAC

ESTMAC D

MOBEX P

DUSTOMAT HYDRO

NA

DUSTMAC P and S

Cyclone ZA

## Industry Applications

- » Aircraft Industry
- » Automotive Repair Shops
- » Blasting Cabinets
- » Chemical Industry
- » Construction Industry
- » Dental Labs
- » Electronics Industry
- » Furniture Industry
- » Glass Production
- » Graphite Processing
- » Laboratories
- » Leather Processing
- » Machine Building Industry
- » Metalworking Industry
- » Model Building
- » Natural and Man Made Stone Processing (Stone Masons)
- » Paper Manufacturing
- » Pharmaceutical Industry
- » Plastics Processing
- » Precision Mechanical Work
- » Printing Industry
- » Recycling-Companies
- » Sandblasting Shops
- » Sawmills
- » Schools
- » Shoe Manufacturers
- » Steel Construction
- » Textile and Flocking Industry
- » Woodworking Companies



## Test Certificates



## Device overview according to harmful substances

	Dust Extractors												
	TK 4 / TK 6 / TK 2.2	OM	DUSTOMAT 100-S – 160-S	DUSTOMAT-10 / -16M	DUSTOMAT DRY	DUSTOVAC	ESTMAC D	MOBEX P	DUSTOMAT HYDRO	Wet separator NA	DUSTMAC P	DUSTMAC S	Cyclonic pre-separator ZA
Page	9	10	11	12	14	16	17	18	20	22	23	25	26
Aluminum dust									•	•			
Cotton fibres	•	•	•									•	
Concrete dust				•		•		•			•		
Chemical dust				•	•			•	•	•	•	•	•
CRP-/GRP-shavings	•	•										•	
Dental dusts						•							
Pigments				•		•		•					
Moist dusts									•	•			
Flock dusts	•	•	•									•	
Lint			•									•	•
Foil tinsel	•	•	•									•	
Odors													
Spice dust				•		•		•			•		
Glass dust	•	•		•		•		•			•		
Graphite powder				•		•		•			•		
Rubber and leather dust	•	•		•		•		•	•	•	•	•	•
Plastic shavings	•	•		•		•	•	•				•	•
Plastic dusts	•	•		•	•	•	•	•			•	•	
Sticky dust			•						•	•			
Chalk				•		•		•				•	
Flour dust				•		•		•			•		
Metal shavings	•	•		•		•	•	•				•	•
Metal shavings (fraught emulsion)												•	
Metal dusts	•	•		•	•	•	•	•	•	•	•	•	•
Mineral dusts				•		•		•			•	•	
Oil mist/aerosols													
Paper dust				•	•	•		•			•		
Scraps of paper	•	•	•									•	
Soot						•						•	•
Welding Fume													
Stone dust				•		•		•			•	•	
Tabacco fibres				•									
Textile fibres	•	•	•									•	
Toner dust				•				•				•	
Cement dust				•		•		•			•	•	

This table lists only the best-known types of dust and does not claim to be complete. It serves for orientation and pre-selection of the suitable device. Before final purchase, however, you should contact the experts at ESTA, as this pre-selection should be checked again on the basis of a number of factors such as process, grain size or characteristics of the material. Service Hotline: **+49 7307 3409680-0**

## Introduction and Product Overview

### Introduction

Dust extractors play a crucial role near processing machines and in production halls. With the right type of filter, nearly all types of shavings and dusts can be separated. Dust extraction is done directly through the device's connection piece or through capture elements such as exhaust hoods or extraction arms.



### Product overview

Small dust extractors in the **TK** and **OM series** have a manually cleanable bag filter. They are mainly placed under processing machines or work-benches. Mobile dust extractors of the serie **DUSTOMAT** are more economical than a central system. They are recommended when extraction points frequently change. Their compact design makes them smooth-running and flexible to use. This class includes the **DUSTOMAT-10** and **16 M.**

The compact dust extractors of the **DUSTOMAT DRY** series are suitable for almost all purposes thanks to their versatile configurations, and, among other things, effectively extract dusts that occur when processing metal and plastic (separation efficiency of up to 99.995 %).

Thanks to aerodynamic optimisation, the filters of the **DUSTOMAT DRY** series have even higher energy efficiency compared to their predecessors. The innovative filter cleaning system also offers users significant savings potential: thanks to compressed air savings of up to 50 percent and extended filter service life, follow-up costs are reduced to a minimum.

The mobile dust extractors **DUSTOMAT S** were specifically designed for the extraction of sticky and fibrous dust.

The dry dust extractors of the **ESTMAC D**-series are suitable as compact and inexpensive extraction solutions for the lower to medium performance segment. The units extract dry and free-flowing dust and offer a wide range of applications for many industries.



## Introduction and Product Overview

**MOBEX** compact dust extractors are developed for professional dust extraction. The devices have automatic filter cleaning and can be used in continuous operation.

The new wet separators of the **DUSTOMAT HYDRO** series are ideal for work processes with flying sparks, as well as for the extraction of highly flammable substances. The innovative water separation technology safely binds over 98,7 % of the extracted dusts and sparks in water, even with the smallest particle fractions of  $\geq 15 \mu\text{m}$ . The downstream dry filter system (separation efficiency up to  $\geq 99.995 \%$ ) is therefore low-wear and thus reduces follow-up costs. The filter system can be configured individually.

**NA** wet separators are especially good for extracting flying sparks or sticky dusts. These devices perform filtration through a water bath. For extracting explosive aluminium dusts, we also offer wet separators in specially tested designs.

The **DUSTMAC** series contains high-performance dust extractors that can extract from several machines at the same time through a pipe system.

**DUSTMAC** systems have a modular design, which allows later system expansion, if necessary.

The stationary **Cyclone Separator ZA** will be installed in front of the actual filter unit, for the pre-separation of dry, pourable dust.



### Easy to operate and maintain

What all these devices have in common is that they are easy to operate and maintain. This lets you focus on your work – not on extraction.

The detachable dust collection drawer and ESTA's tiltable filter housings guarantee trouble-free disposal of collected dust material.

Clear, ergonomically arranged control elements allow safe, simple handling.



Dust Extractors

High Vacuum  
Extraction Units

Welding Fume  
Filters

Oil Mist  
Separators

Carbon Filters/  
Air Purifier

Downdraft  
Tables

Extraction Fans

Extraction Arms

Filter Towers

Central Extraction  
Systems

Pipe Systems

About us

Interesting  
Information

## Advantages that Pay Off

### Flexible use

Smooth-turning rollers help move ESTA mobile dust extractors to their desired location, ensuring flexible application. Mobile undercarriages are available for small and compact dust extractors. Various filter media and filter-cleaning systems allow use in nearly any application or industry. For adapting the devices optimally to local conditions, many versions are available:

- » Custom voltages
- » Sensors and actuators
- » Exhaust outlet
- » Activated carbon filters
- » Special filters
- » Pre-separators
- » Special paint treatments
- » ... and much more

### Quality and expertise

Air technology design based on decades of experience, the latest technical knowledge and scientific evaluation of empirical data are the reasons our dust extractors are ever more innovative. Investments in this area stand up to every audit.



### Quality workmanship

The high quality our customers demand ensures our dust extractors last a long time. We assure this quality standard through:

- » Highly qualified employees
- » Internal device inspection and final inspections
- » Audited production facilities
- » External device test certificates
- » Production certified per DIN EN ISO 9001:2008 from DEKRA, IFA, etc.



### A comprehensive range of accessories

So that our dust extractors can be used effectively at any extraction point, we offer a complete range of accessories:

Such as:

- » Cyclonic separators
- » Spark pre-separators
- » Pipe pre-separator
- » Hoods and extraction arms
- » Pipes, hoses and connectors

### Operating costs

Cleanable permanent filter cartridges, precisely adapted cleaning methods and components made for continuous operation minimize failure, equipment and replacement part costs.

Productivity and economy both improve, and ESTA has one more satisfied customer.



### On-site installation

From consultation to on-site installation. We design tailor-made solutions and build them, too – the customer gets one-stop shopping.

Excellent project planning and implementation are the basis for reliable, well-functioning extraction systems.

## Mini Dust Collectors TK and TK 2.2



Mini dust collector TK

### Application Range

- » Extraction of individual workstations in industry and trade
- » For direct extraction of grinding, milling, and deburring
- » For occasional use in little amounts of dust
- » Mechanical workshops
- » Metalworking companies

### Special Versions

- » High efficiency filter materials for very fine dust
- » Motors in three phase or alternating current
- » Mobile unit with casters
- » Sound dampening muffler
- » Custom paint finish
- » Filtration unit only, without motor
- » Equipped with a turbine blower for applications requiring very high vacuum power (TK-2.2)



### Ideal for

- Metal dust
- Metal shavings
- Plastic shavings
- ... and many more



Mini dust collector TK connected to a deburring machine

**ESTAPLUS**

### Special Features

- » Cleanable, durable bag filter dust class M
- » Heavy duty dust collection drawer

### Your Benefits

- » Small space requirement due to compact design
- » Easy to handle
- » Low operating costs due to cleanable filter bag
- » Low maintenance

Data dependent on equipment type

### Technical Data

Model		TK-4	TK-6	TK-2.2
Max. volume flow	cfm	300	450	300
Intake opening	mm	60	80	50
Max. negative pressure	Pa	1.400	1.400	21.000
Mains voltage	V	400	400	400
Nominal power	HP	0.55	0.55	2.2
Motor speed	1/min	2.800	2.800	2.800
Dimensions (L/W/H)	mm	400 x 400 x 590	400 x 400 x 590	830 x 460 x 655
Overall depth	mm	600	600	900
Weight	kg	45	30	106
Sound pressure level	dB(A)	68	68	75
<b>Order Number</b>		<b>31.041</b>	<b>31.061</b>	<b>41.033</b>

Dust Extractors

High Vacuum Extraction Units

Welding Fume Filters

Oil Mist Separators

Carbon Filters/ Air Purifier

Downdraft Tables

Extraction Fans

Extraction Arms

Filter Towers

Central Extraction Systems

Pipe Systems

About us

Interesting Information

## Mini Dust Collectors OM



Mini dust collector OM

### Application Range

- » Intermittent or continuous duty use with moderate quantities of dust
- » Electronics industry
- » Metalworking industry
- » Surface finishing technology
- » Machine building



### Ideal for

- Metal dust
- Metal shavings
- Plastic dust
- ... and many more

### Special Versions

- » High efficiency filter material for very fine dust – also available with certification for dust classification M
- » Motors in three phase or alternating current
- » Custom paint finish
- » Water pre-separator for spark generating applications
- » Mobile unit with casters
- » Sound dampening muffler



OM-8 connected to a belt sanding machine

**ESTA PLUS**

### Special Features

- » Cleanable, durable bag filter
- » Heavy duty dust drawer

### Your Benefits

- » Suitable for nearly all types of dust
- » Versatile in its use
- » Cleanable long life filter
- » Low operating costs due to cleanable filter bag
- » Small space requirement due to compact design

Data dependent on equipment type

### Technical Data

Model		OM-8	OM-10	OM-12
Max. volume flow	cfm	500	600	800
Intake opening	mm	80	100	150
Height of intake connection	mm	300	300	300
Max. negative pressure	Pa	1.600	1.500	1.800
Mains voltage	V	400	400	400
Nominal power	HP	0.55	0.55	1.10
Dimensions (L/W/H)	mm	550 × 550 × 1.120	550 × 550 × 1.120	550 × 550 × 1.120
Overall depth	mm	670	670	670
Weight	kg	65	65	70
Sound pressure level	dB(A)	65	66	72
<b>Order Number</b>		<b>21.081</b>	<b>21.101</b>	<b>21.122</b>

## Mobile Dust Extractors *DUSTOMAT S Series*

### Application Range

- » Specialized dust extractor for sticky dust and dust containing long fibres
- » Textile and flocking industry



#### Ideal for

- Flock dusts
- Foil tinsel
- Sticky dust
- Textile fibres
- Cotton dust
- ... and many more



DUSTOMAT S



DUSTOMAT 160-S in OEM-version for dust extraction on a manual flocking workstation

**ESTA PLUS**

### Special Features

- » Fabric filter element with primary paper filter bag

### Your Benefits

- » Compact design with high extraction performance
- » Easily replaceable paper filter bag to collect the dust

Data dependent on equipment type

### Technical Data

DUSTOMAT		100-S	120-S	140-S	160-S
Max. volume flow	cfm	720	1.060	1.330	1.850
Intake opening	mm	100	125	140	160
Max. negative pressure	Pa	2.800	3.250	3.800	4.600
Mains voltage	V	230/400	400	400	400
Nominal power	HP	1.3/1.1*	2.2	3.0	3.0
Main filter surface	m <sup>2</sup>	0.75	1	1	1
Collection volume	l	100	200	200	200
Dimensions (L/W/H)	mm	1.075 x 530 x 1.075	1.653 x 782 x 1.353	1.653 x 782 x 1.353	1.653 x 782 x 1.373
Weight	kg	70	190	200	200
Sound pressure level	dB(A)	71	68	69	73

### Order Number

Model	230 V	09.500	-	-	-
Model	400 V	09.497	09.502	09.504	09.506

\* 400V-model

Dust Extractors

High Vacuum Extraction Units

Welding Fume Filters

Oil Mist Separators

Carbon Filters/Air Purifier

Downdraft Tables

Extraction Fans

Extraction Arms

Filter Towers

Central Extraction Systems

Pipe Systems

About us

Interesting Information

# Dust Extractors

## Mobile Dust Extractors *DUSTOMAT-10*



DUSTOMAT-10

### Application Range

- » Dust extraction of individual machines and manual workstations
- » Pourable dust types – including hazardous types of dust



### Ideal for

- Metal shavings
- Plastic dust
- Pigments
- Tabacco fibres
- Paper dust
- Metal dust
- ... and many more



DUSTOMAT-10 with accessories for floor clean up

**ESTA**PLUS

### Special Features

- » Brush cleaning method (manually)
- » Cleanable long life cartridge filters (Dust classification M)

### Your Benefits

- » Low operating costs resulting from cleanable long life filter cartridges
- » Mobility combined with high extraction performance
- » Tilt-back filter housings for easy dust disposal
- » Suitable for most types of dust

Data dependent on equipment type

### Technical Data

DUSTOMAT-		10
Max. volume flow	cfm	720
Intake opening	mm	100
Max. negative pressure	Pa	2.800
Mains voltage	V	230/400
Nominal power	HP	1.3/1.1*
Main filter surface	m <sup>2</sup>	3.5
Dimensions (L/W/H)	mm	1.165 × 530 × 1.636
Weight	kg	120
Sound pressure level	dB(A)	73
Order Number		
Manual filter cleaning	(230 V)	<b>09.201</b>
Manual filter cleaning	(400 V)	<b>09.215</b>

\* 400 V-model

## Mobile Dust Extractors *DUSTOMAT-16 M*



DUSTOMAT-16 M with extraction arm

### Application Range

- » Dust extraction of individual machines and manual workstations
- » Especially designed for extracting mineral dusts at changing workstations in the stone industry

### Special Versions

- » ATEX version (16M)

### Accessories

Special accessories for the DUSTOMAT series, such as extraction arms, floor cleaning set, various nozzles, pre-separators, etc. for the DUSTOMAT series can be found in our accessories catalogue.



### Ideal for

- Stone dust
- Mineral dusts
- Spice dusts
- Organic dusts
- Chemical dusts
- ... and many more



DUSTOMAT-16M  
– direct extraction of fine stone dust

ESTAPLUS

### Special Features

- » Two filter cleaning methods:
  - pulse jet cleaning method
  - pneumatic filter cleaning
- » Cleanable long life cartridge filters (Dust classification M)

### Your Benefits

- » Low operating costs resulting from cleanable long life filter cartridges
- » Mobility combined with high extraction performance
- » Tilt-back filter housings for easy dust disposal
- » Suitable for most types of dust

Data dependent on equipment type

### Technical Data

DUSTOMAT-		16 M
Max. volume flow	cfm	1.140
Intake opening	mm	125
Max. negative pressure	Pa	2.000
Mains voltage	V	230/400
Nominal power	HP	1.3/1.1*
Main filter surface	m <sup>2</sup>	9.4
Dimensions (L/W/H)	mm	1.150 × 670 × 1.470
Weight	kg	110
Sound pressure level	dB(A)	77
Order Number		
Pneumatic filter cleaning	(230 V)	<b>09.420</b>
Pneumatic filter cleaning	(400 V)	<b>09.421</b>
Pulse jet filter cleaning	(400 V)	<b>09.422</b>
ATEX version	(400 V)	<b>09.423</b>

\* 400V-model

Dust Extractors

High Vacuum  
Extraction Units

Welding Fume  
Filters

Oil Mist  
Separators

Carbon Filters/  
Air Purifier

Downdraft  
Tables

Extraction Fans

Extraction Arms

Filter Towers

Central Extraction  
Systems

Pipe Systems

About us

Interesting  
Information

**NEW**

## Mobile Dust Extractors *DUSTOMAT DRY*



DUSTOMAT DRY

**ESTA PLUS**

### Special Features

- » Available in four output levels
- » Variable cleaning system, depending on the application
- » 50% compressed air savings thanks to innovative jet pulse filter cleaning system
- » Integrated impact separator for pre-separation of coarse and heavy particles

### Your Benefits

- » Configurable: extraction power, filter package and system design
- » Strong extraction power for optimal extraction results
- » Aerodynamically optimised design for efficient air flow, resulting in low operating costs
- » Low-noise system operation
- » Recirculation/exhaust air operation possible
- » Compact design
- » Mobile dust collection drawer for easy disposal
- » Sturdy, durable steel construction
- » Intuitive operation via a convenient touch display
- » High level of operation and maintenance friendliness

Data dependent on equipment type

### Application Range

- » Extraction of dry and free-flowing dusts and chips
- » Depending on the design, can also be used for carcinogenic, flammable or explosive media
- » Suitable for many applications, also for flying sparks
- » Single and multi-user extraction for industry and commerce
- » For direct extraction at processing machines
- » For connection to extraction arms, extraction tables, extraction hoods as well as shorter pipe systems

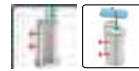
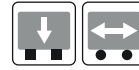

### Ideal for

- Metal dust
- Metal filings
- Chemical dust
- CFK/GFK-dust
- Lint
- ... and many more

### Special Versions

- » ATEX design
- » Pre-separator for sparks, chips and dusts
- » HEPA H 14 filter (separation efficiency up to 99.995%)
- » Downstream activated carbon filter for odour neutralisation
- » Version with frequency converter
- » Stationary version
- » Version with exhaust air connection piece
- » Variable positioning of intake connection piece, touch display, control cabinet, etc.
- » Other versions on request



The small space requirement and the low operating noise of the deduster allow installation directly in the work area.



**NEW**

## Mobile Dust Extractors *DUSTOMAT DRY*



### Technical Data

<b>DUSTOMAT DRY</b>		<b>2000</b>	<b>2700</b>	<b>3300</b>	<b>3500</b>
Max. volume flow	cfm	2,000	2,700	3,100	3,500
Max. negative pressure	Pa	2,400	2,900	3,400	4,500
Intake opening	mm	160	180	200	200
Mains voltage	V	400	400	400	400
Nominal power	kW	2.2	3.0	4.0	5.5
Circuit breaker	A	C16	C16	C16	C16
Compressed air connection	Inch	¾"	¾"	¼"	¼"
Main filter quantity	Piece	2	2	2	2
Main filter surface	m <sup>2</sup>	10	10	20	20
Collection volume	l	50	50	50	50
Dimensions (L/W/H)	mm	1,630 × 840 × 1,430	1,630 × 840 × 1,430	1,630 × 840 × 1,680	1,630 × 840 × 1,680
Weight	kg	300	300	330	330
Sound pressure level	dB(A)	66	68	71.5	75
<b>Order Number</b>					
Standard		<b>X09700</b>	<b>X09701</b>	<b>X09702</b>	<b>X09703</b>

Dust Extractors

High Vacuum  
Extraction Units

Welding Fume  
Filters

Oil Mist  
Separators

Carbon Filters/  
Air Purifier

Downdraft  
Tables

Extraction Fans

Extraction Arms

Filter Towers

Central Extraction  
Systems

Pipe Systems

About us

Interesting  
Information

# Dust Extractors

## High vacuum dust extractor *DUSTOVAC*



DUSTOVAC

### Application Range

- » Single and multiple-placedust-extraction in industry and trade
- » Free-flowing dust
- » Dry chips

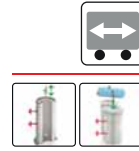

### Ideal for

- Concrete dust
- CFRP / GFRP dust
- Colour pigments
- Plastic chips
- Plastic dust
- Metal chips
- Metal dust
- Mineral dust
- Stone dust
- ... and many more



Applying DUSTOVAC

### Special features

- » Two filter cleaning methods: manual and jet-cleaning
- » Cleanable permanent filter-cartridges (dust class M)

### Your benefits

- » High suction power for point-exact extraction with handheldpowertools
- » Low operating costs
- » Low-noise and usable in multi-layer operations
- » Patented tiltable filter housing for easy disposal of grouped goods
- » Suitable for almost all kinds of dust
- » Collection volume 200 litres

Data dependent on equipment type

### Technical Data

DUSTOVAC		5.5	7.5	13.0
Max. volume flow	cfm	480	850	1.100
Intake opening	mm	70	100	125
Max. negative pressure	Pa	24.500	25.000	22.000
Mains voltage	V	400	400	400
Nominal power	HP	5.5	7.5	13.0
Main filter surface	m <sup>2</sup>	9.6	9.6	9.6
Dimensions (L/W/H)	mm	1.830 × 782 × 2.040	1.830 × 782 × 2.040	1.830 × 782 × 2.040
Weight	kg	230	334	390
Sound pressure level	dB(A)	68	77	79

### Order Number

Manual filter cleaning	<b>83.109</b>	<b>83.103</b>	<b>83.104</b>
Pulse-jet filter cleaning	<b>83.112</b>	<b>83.107</b>	<b>83.108</b>

## Compact dust extractor *ESTMAC D*



### Application Range

- » Single and multi-user extraction of free-flowing and dry dust
- » Suitable for many applications
- » For direct suction on processing machines
- » For connection to collection hoods, extraction arms and smaller pipe systems



### Ideal for

- Cuttings
- Metal dust
- Plastic dust
- Chipped plastics
- Dirt and chips
- ... and many more

### Special versions/accessories

- » Afterfilter cassette (dust class H)
- » Pre-separator for sparks, chips and dust
- » Activated carbon filter
- » Mobile version
- » Special enamel

### Special features

- » Available in two power levels
- » Integrated impact separator for pre-separation of coarse and heavy particles
- » Cleaning by means of manual rotation nozzle

### Benefits for you

- » Strong suction power in combination with compact utility space
- » Innovative device design ensures efficient air flow guidance, thus low operating and follow-up costs
- » Low operating noise; can, therefore, be installed directly in the working area
- » Mobile dust collection drawer for easy disposal
- » Robust processing of steel sheet for a long service life
- » High operating and maintenance friendliness

Data depending on model version



### Technical Data

ESTMAC D		1500	1800
Max. volume flow	cfm	1.500	1.800
Intake opening	mm	160	160
Max. negative pressure	Pa	2.040	2.650
Mains voltage	V	400	400
Nominal power	HP	1.1	2.2
Main filter surface	m <sup>2</sup>	7.5	15
Main filter quantity	Piece	1	2
Collection volume	l	40	40
Dimensions (L/W/H)	mm	710 × 790 × 1.690	710 × 790 × 1.690
Weight	kg	170	180
Sound pressure level	dB(A)	71	73
<b>Order Number</b>		<b>099.150</b>	<b>099.180</b>

## Compact Extractor *MOBEX P*



MOBEX P-24

**ESTA**PLUS

### Special Features

- » Innovative sandwich-panel housing design
- » Pre-separation system with integrated impact separator on the raw gas inlet
- » Jet pulse cleaning
- » A new disposal system with lockable dust collection cartons (tested by the IFA)
- » Optional: Mobile version available

### Your Benefits

- » High suction performance
- » Low operating costs thanks to cleanable permanent filter
- » Long filter life due to a pre-separation system
- » Low operating noise thanks to a sound-insulated housing
- » Small space requirement due to compact design
- » Easy, dust-free removal of collected material through a new disposal system

Data dependent on equipment type

### Application Range

- » Universal use for dusts and shavings in the metal and plastics industries and many others
- » Single- or multiple-location extraction at machines that produce dust or shavings, or at welding stations
- » Polishing workplaces, for example in the shoe industry, instrument making, etc.



### Ideal for

- Metal dust
- Metal shavings
- Plastic shavings
- Plastic dust
- ... and many more

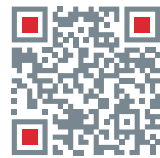

Product-Video

### Special Versions

- » Special filter materials
- » Special voltage
- » Pipe pre-separator
- » Exhaust air connection
- » ATEX version
- » Test certificate H



The MOBEX-dust extractors can also be used in combination with an ESTA Extraction table.



MOBEX P-24 at a milling machine

## Compact Extractor *MOBEX P*

**ESTA Control** is the specially developed device control that ensures energy-efficient device operation. **Power savings of up to 50%** compared to conventional differential pressure controls are obtained through current volume flow measurement and the fully-automated regulation of the extraction performance based on the operating parameters.



The detachable dust collection drawer with lockable cartons ensures simple, dust-free disposal.

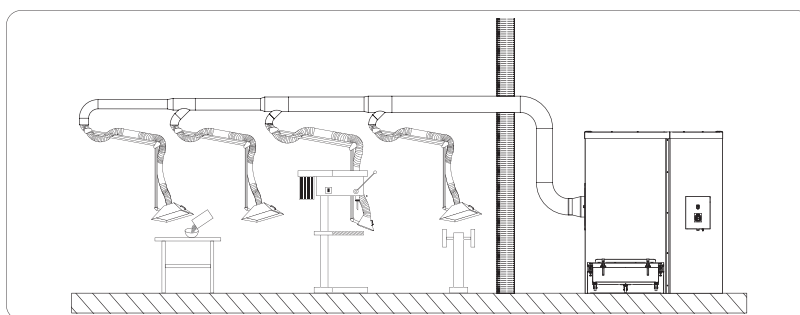

With pipelines, the MOBEX series can be used for simultaneous extraction at multiple workstations.

### Technical Data

MOBEX		P-24	P-36	P-50
Max. volume flow	cfm	3.300	4.500	5.600
Intake opening	mm	200	250	280
Max. negative pressure	Pa	3.400	3.400	3.300
Mains voltage	V	400	400	400
Nominal power	HP	3.0	4.0	4.0*
Main filter quantity	Piece	2	3	4
Main filter surface	m <sup>2</sup>	24	36	48
Collection volume	l	100–150 (2 × 38**)	100–150 (2 × 38**)	100–150 (2 × 38**)
Dimensions (L/W/H)	mm	1.910 × 1.040 × 2.035***	2.030 × 1.040 × 2.035***	2.030 × 1.040 × 2.030***
Weight	kg	310	350	415
Sound pressure level	dB(A)	71	74	77
<b>Order Number</b>				
Standard		<b>09.831</b>	<b>09.832</b>	–
Tested to dust class H		<b>09.833</b>	<b>09.834</b>	–
ATEX version		<b>09.840</b>	<b>09.841</b>	–

\* Different impeller \*\* with dust collection box \*\*\* without spark trap

**NEW**

Wet separator

## DUSTOMAT HYDRO



CLEAN THE AIR  
SAVE THE OCEAN



### Ideal for

- Metal dust
- Stainless steel dust
- Aluminium dust
- Titanium dusts
- Cuttings
- ... and many more



### Application Range

- » Single and multi-station extraction for industry and trade
- » Extraction of metallic dusts that produce flying sparks
- » Suitable for machining high-alloy and unalloyed steels as well as titanium and aluminium (DGVV 109-001)
- » Suitable for extracting explosive materials (ATEX-compliant)
- » As a central extraction unit with collecting pipe and several extraction points

### Specialized Models and Options

- » ATEX-compliant design
- » Sound insulation package
- » Selectable filter media
- » Variable position of the intake manifold

**ESTA PLUS**

### Special Features

- » Innovative water separation technology (separation efficiency >98.7% – even with the smallest particle size of 15 µm)
- » Configurable filter system (up to 4 filter stages possible)
- » Optional HEPAH 14 filter (separation efficiency ≥ 99.995%) for carcinogenic substances
- » Automatic water filling monitored by sensors

### Your Benefits

- » Strong extraction power combined with maximum efficiency
- » Safe solution for flying sparks
- » High separation efficiency thanks to multi-stage filtration
- » Compact design
- » Low-noise system operation
- » Economical energy and water consumption
- » Recirculation/exhaust air operation possible
- » Easy to operate and maintain
- » Low running costs

Data dependent on equipment type



**NEW**

Wet separator

## DUSTOMAT HYDRO

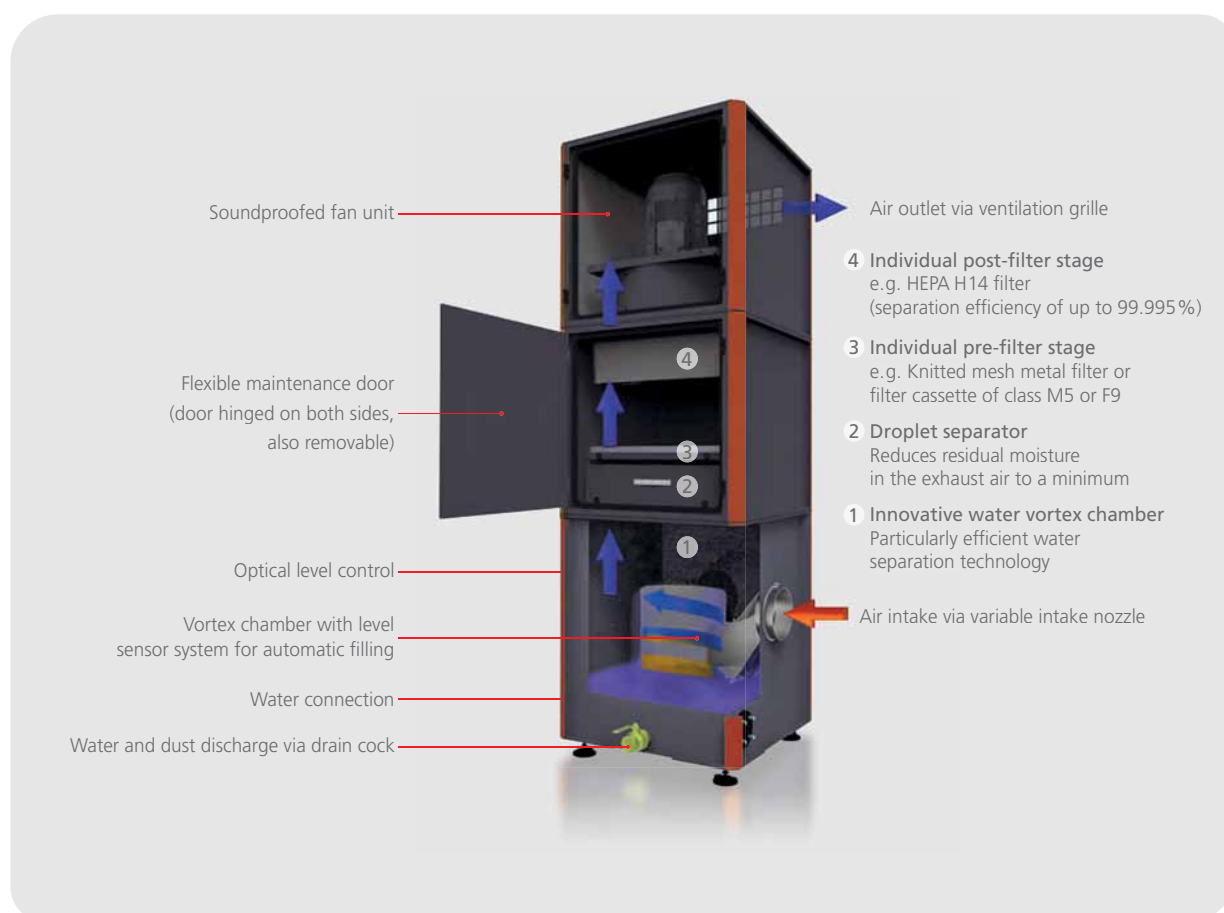

### Technical Data

DUSTOMAT HYDRO		2300	3500	6000	10000
Max. volume flow	cfm	2,300	3,500	6,000	10,000
Max. negative pressure	Pa	2,500	3,400	3,950	4,800
Connection diameter	mm	180	224	280	400
Nominal power	HP	3.0	5.5	7.5	15.0
Water connection	Zoll	3/4	3/4	3/4	3/4
Dimensions (L/W/H)	mm	850 × 850 × 2,600	850 × 850 × 2,600	1,350 × 1,550 × 3,400	1,350 × 1,550 × 3,400
Weight	kg	340	380	750	870
Sound pressure level	dB(A)	70.0	72.0	73.4	76.1
<b>Order Number</b>					
Standard		<b>X45900</b>	<b>X45900</b>	<b>X45900</b>	<b>X45900</b>

- Dust Extractors
- High Vacuum Extraction Units
- Welding Fume Filters
- Oil Mist Separators
- Carbon Filters/Air Purifier
- Downdraft Tables
- Extraction Fans
- Extraction Arms
- Filter Towers
- Central Extraction Systems
- Pipe Systems
- About us
- Interesting Information

## Wet Separators

### NA-1.1 / NA-2.2 SK



Wet Separator NA-500

#### Application Range

- » Extraction of sticky substances and dusts
- » Spark generating production processes
- » Extraction of flammable, explosive and dry substances defined as "Zone22" types of dust (ATEX version)



#### Ideal for

- Metal dust
- Sticky dust
- Flammable dusts
- ... and many more

#### Special Versions

- » As a pre-separator for existing dust extractor (NA-500)
- » As vacuum unit (NA-2.2)
- » Stainless steel housing
- » ATEX-approved version
- » Magnetic valve for automatic water supply



Tilt-back upper housing for easy access to the interior of the unit

**ESTA PLUS**

#### Special Features

- » Three different versions for mobile wet separation
- » Droplet separator and filter cartridge of dust classification M

#### Your Benefits

- » Tilt-back upper housing for easy dust disposal
- » Small space requirement due to compact design
- » Minimum water consumption

Data dependent on equipment type

#### Technical Data

NA		-1.1 Dust Extractor	-2.2 Vacuum unit
Max. volume flow	cfm	560	300
Intake/outlet diameter	mm	100/-	50/-
Max. negative pressure	Pa	1.700	21.000
Nominal power	HP	1.1	2.2
Water capacity	l	40	40
Collection container	l	100	100
Dimensions (L/W/H)	mm	1.310 × 530 × 1.560	1.260 × 630 × 1.560
Weight (without Water)	kg	120	130
Sound pressure level	dB(A)	78	68
<b>Order Number</b>			
Standard version		<b>45.511</b>	<b>45.512</b>
Stainless steel version		<b>45.611</b>	<b>45.612</b>
ATEX version		-	<b>45.712</b>



## Modular Dust Extractors

### DUSTMAC P (Cartridge Filters)



DUSTMAC P (with cartridge filters)

#### Application Range

- » Central extraction of multiple dust generating machines
- » Suitable for dry, pourable types of dust



#### Ideal for

- Chemical dust
- CRP-/GRP-dusts
- CRP-/GRP-shavings
- Metal dust
- Mineral dust
- Stone dust
- ... and many more

#### Special Versions

- » Special filter materials
- » Custom paint finish
- » Fan with various capacities
- » Coating for outdoor installation
- » Pipe pre-separator
- » Pre-separator
- » ATEX version



The DUSTMAC series is also suitable for outdoor installation

**ESTAPLUS**

#### Special Features

- » Pulse-jet filter cleaning system
- » Integrated Pre-separator
- » Cleanable long life cartridge filters (Dust classification M)

#### Your Benefits

- » Suitable for most types of dust
- » Low operating costs due cleanable filter cartridges
- » Modular design (expandable)
- » Customer specific design

Data dependent on equipment type

#### Technical Data

DUSTMAC		P-20	P-40	P-60	P-90	P-144
Max. volume flow	cfm	ca. 2.600	ca. 4.500	ca. 7.800	ca. 9.700	ca. 15.000
Intake/outlet diameter	mm	160/280	224/355	280/300	355/450	450/560
Max. negative pressure	Pa	2.000	3.200	3.800	3.800	5.050
Mains voltage	V	400	400	400	400	400
Nominal power	HP	2.2	4.0	5.5	7.5	15.0
Main filter surface	m <sup>2</sup>	20	40	60	90	144
Main filter quantity	Pieces	2	4	6	9	9
Collection volume	l	100	100	100	100	100
Dimensions (L/W/H)	mm	1.310 × 1.055 × 3.250	1.310 × 1.300 × 3.295	1.750 × 1.300 × 3.740	1.900 × 1.880 × 3.770	1.730 × 1.810 × 4.010
Sound pressure level	dB(A)	67	73	78	83	83
<b>Order Number</b>		<b>661.020</b>	<b>661.040</b>	<b>661.060</b>	<b>661.090</b>	<b>661.144</b>

Dust Extractors

High Vacuum  
Extraction Units

Welding Fume  
Filters

Oil Mist  
Separators

Carbon Filters/  
Air Purifier

Downdraft  
Tables

Extraction Fans

Extraction Arms

Filter Towers

Central Extraction  
Systems

Pipe Systems

About us

Interesting  
Information

# Dust Extractors

## Modular Extractors

### *DUSTMAC S (Tubular Bag Filters)*



DUSTMAC S (with tubular bag filters)

#### Application Range

- » Central extraction of multiple industrial dust generating work-stations or machines
- » Suitable for fine, fibrous and sticky types of dust



#### Ideal for

- Cotton dust
- Chemical dust
- CRP-/GRP-dusts
- Flock dust
- Plastic dust
- Chalk
- Metal shavings
- Paper strips
- Soot
- Cement dust
- ... and many more

#### Special Versions

- » Special filter materials
- » Custom paint finish
- » Fan with various capacities
- » Coating for outdoor installation
- » Pre-Separator
- » ATEX-approved version optional



Central extraction systems with two DUSTMAC S filter modules each

**ESTA**PLUS

#### Special Features

- » Pulse-jet filter cleaning system
- » Cleanable long life tubular bag filters for dust classification M

#### Your Benefits

- » Low operating costs due cleanable filter cartridges
- » Modular design (expandable)
- » Customer specific design

Data dependent on equipment type

#### Technical Data

DUSTMAC		S-5	S-10	S-17	S-25	S-33
Max. volume flow	cfm	ca. 2.600	ca. 3.500	ca. 4.500	ca. 5.400	ca. 9.700
Intake/outlet diameter	mm	160/280	200/300	224/355	280/400	355/400
Max. negative pressure	Pa	2.000	2.600	3.200	3.200	3.800
Mains voltage	V	400	400	400	400	400
Nominal power	HP	2.2	3.0	4.0	5.5	7.5
Main filter surface	m <sup>2</sup>	5	10.5	17	25	33
Hoses	Pieces	13	20	32	48	48
Collection volume	l	50	50	50	50	50
Dimensions (L/W/H)	mm	1.400 × 1.055 × 3.465	1.400 × 1.310 × 3.470	1.820 × 1.310 × 3.875	1.820 × 1.750 × 3.990	1.880 × 1.750 × 4.400
Sound pressure level	dB(A)	67	69	74	76	82

**Order Number**      **662.005**   **662.010**   **662.017**   **662.025**   **662.033**

Additional informations about the modular extractor DUSTMAC can be found beginning on page 82

## Cyclone Pre-Separators ZA



Cyclone Pre-Separator ZA

### Application Range

- » Can be used as primary filtration unit or pre-separator unit
- » For dry, pourable types of dust

Because we at ESTA are convinced of the effectiveness of our cyclone geometry, we issue an "extraction guarantee declaration".



### Ideal for

- CRP-/GRP-dusts
- Chemical dust
- Rubber and leather dust
- Wood shavings
- Plastic shavings
- Metal shavings
- ... and many more

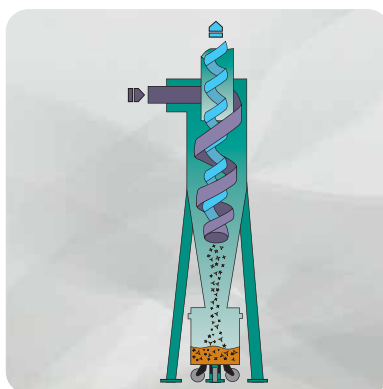

Schematic description of product mechanics



Cyclone pre-separator ZA-160 application photo

**ESTA PLUS**

### Special Features

- » Collection volume available in different sizes
- » Different discharge methods (sluices, rotary valve)
- » As steel, stainless steel or aluminum version available
- » Coating for outdoor installation

### Your Benefits

- » Optimal solution for extracting medium sized and coarse dust
- » Can be combined ideally with other ESTA dust extractors
- » Extraction guarantee declaration for your type of dust

Data dependent on equipment type

### Technical Data

Cyclone pre-separator	Intake connection mm	Airflow volume Intervall cfm	Collection container Liter	Height of cyclone mm	Order Number
ZA 50	50	-200	50	1.458	20820050
ZA 100	100	-800	100	2.280	20821100
ZA 125	125	-1.100	100	2.596	20821125
ZA 140	140	-1.200	100	2.578	20821140
ZA 160	160	-2.000	100	2.924	20821160
ZA 200	200	-2.500	100	3.166	20821200
ZA 225	225	-3.700	200	4.128	20822225
ZA 250	250	-4.500	200	4.399	20822250
ZA 280	280	-6.000	200	4.823	20822280
ZA 300	300	-6.500	200	5.086	20822300
ZA 315	315	-7.500	200	5.278	20822315
ZA 355	355	-9.300	200	5.735	20822355
ZA 450	450	-12.500	200	6.449	20822450

The sound level rating depends on the type of fan installed in the equipment

# High Vacuum Extraction Units

For Heavy Duty Clean-Up of Machines, Floors and Workstations

EUROSOG-W / -I-D

DUROSOG-W / -I-D

WHISPERSOG

CENTRASOG

CVS 2.0

MULTISOG-1 and 4



## Application Range

- » Automotive Repair Shops
- » Carpenters
- » Chemical Industry
- » Construction Industry
- » Craftsmen's Workshops
- » Flocking Industry
- » Janitorial Services
- » Machine Building Industry
- » Natural and Man-made Stone Processing (Stone Masons)
- » Paper Industry
- » Printing Industry
- » Textile Industry
- » Transportation Businesses
- » Warehouses and Industrial Plants

## Test Certification:



## Device overview according to harmful substances

	High vacuum extraction units					
	EUROSOG-W	EUROSOG-I-D	DUROSOG-W	DUROSOG-I-D	WHISPERSOG	CENTRASOG CVS 2.0
Page	29	30	31	32	33	34
Aluminum dust						
Cotton fibres				•		
Concrete dust	•	•			•	
Chemical dust	•	•	•	•	•	
CRP-/GRP-shavings	•	•			•	
Dental dusts	•	•				
Pigments						
Moist dusts						
Flock dusts			•	•		
Lint			•	•		
Foil tinsel			•	•		
Odors						
Spice dust	•	•				
Glass dust	•	•			•	
Graphite powder	•	•				
Rubber and leather dust	•	•				
Plastic shavings	•	•			•	
Plastic dusts	•	•			•	•
Sticky dust			•	•		
Chalk	•	•				
Flour dust						
Metal shavings	•	•				
Metal shavings (fraught emulsion)						
Metal dusts	•	•	•	•	•	•
Mineral dusts	•	•			•	
Oil mist/aerosols						
Paper dust	•	•	•	•	•	
Scraps of paper			•	•		
Soot						
Welding Fume						
Stone dust	•	•				
Tabacco fibres			•	•		
Textile fibres			•	•		
Toner dust					•	
Cement dust	•	•				

This table lists only the best-known types of dust and does not claim to be complete. It serves for orientation and pre-selection of the suitable device. Before final purchase, however, you should contact the experts at ESTA, as this pre-selection should be checked again on the basis of a number of factors such as process, grain size or characteristics of the material. Service Hotline: **+49 7307 3409680-0**

- Dust Extractors
- High Vacuum Extraction Units
- Welding Fume Filters
- Oil Mist Separators
- Carbon Filters/ Air Purifier
- Downdraft Tables
- Extraction Fans
- Extraction Arms
- Filter Towers
- Central Extraction Systems
- Pipe Systems
- About us
- Interesting Information

# High Vacuum Extraction Units

## Introduction and Product overview

### Introduction

ESTA's range of industrial vacuum cleaners are highly versatile and ideally suited for cleaning machines, floors and working areas. All products are notable for their strong suction performance and high quality workmanship. Tilting filter housing (patented by ESTA), such as in the EUROSOG and WHISPEROG appliances, guarantees the effortless disposal of dust and debris.

### Product overview

The **EUROSOG** is a powerful industrial vacuum cleaner for dry dusts. It comes in both AC and DC versions.

**DUROSOG** machines are very good for sticky dusts and textile lint. The optionally insertable piggyback pre-separator allows these mobile designs also to extract fluid-laden shavings.

The **WHISPEROG** is a very quiet but powerful vacuum especially designed for continuous operation.

The stationary dust extraction system **CENTRASOG CVS 2.0** can be connected up to 3 or 15 suction points via pipe.

The **MULTISOG** models can be used as wet or dry vacuum cleaners.

The series is rounded out by the handy **PRETTYBOY 309** industrial vacuum cleaner.

### Mobile and powerful

ESTA's industrial vacuum cleaners are powerful yet flexible. They are just as suited for occasional use as they are for continuous operation. They boast compact construction and are highly manoeuvrable and mobile thanks to their smooth-running fixed and swivel castors.

### Quality of workmanship

ESTA industrial vacuum cleaners stand for quality. This is ensured by:

- Internal device inspection and final inspections
- Audited production facilities
- External device test certificates from DEKRA, IFA, etc.
- "Made in Germany"

### Comprehensive range of accessories

Effective suction technology requires efficient accessories. To ensure the best possible results, we offer a wide range of accessories for our industrial vacuum cleaners:

- Pre-separation systems
- Suction nozzles
- Pipes and connectors
- and much more



### Custom models

We can also supply many of our appliances to custom specifications, according to your individual requirements:

- Special voltages
- Special filters
- Special finishes
- More customisation options on request



## Industrial Vacuum Cleaner *EUROSOG-W*



EUROSOG-W

### Application Range

- » Clean up work of coarse and fine dust
- » Cleaning of machines in factories and workshops
- » AC version for occasional use



### Ideal for

- Cotton dust
- Wood dust
- Metal dust
- Mineral dust
- Paper dust
- Tabacco fibres
- ... and many more



Thanks to the diagonal tube nozzle, even places that are difficult to access can be freed of dust and dirt.

### Special Features

- » AC version for occasional use (AC powered model with three suction fans)
- » Manual brush cleaning mechanism for cleaning of the cartridge filter
- » Availability of cleanable cartridge filters for dust classifications M and H
- » Test certificates M and H available

### Your Benefits

- » High suction force in dry dust
- » Low operating costs through the use of cleanable long life cartridge filters
- » Tilt-back filter housings for easy dust disposal
- » Small space requirement due to compact design
- » High mobility by smooth turning castors

Data dependent on equipment type

### Technical Data

EUROSOG		-W
Max. volume flow	m <sup>3</sup> /h	360
Intake opening	mm	50
Max. negative pressure	Pa	18.600
Mains voltage	V	230
Nominal power	kW	3 x 1.0
Main filter surface	m <sup>2</sup>	2/5
Collection volume	l	80
Dimensions (L/W/H)	mm	932 x 660 x 1.140
Weight	kg	76
Sound pressure level	dB(A)	74

### Order Number

EUROSOG-W – Standard model	<b>80.198</b>
EUROSOG-W/H with TÜV-certificate for dust classification H	<b>80.299</b>
EUROSOG-W/M with TÜV-certificate for dust classification M	<b>80.399</b>

# High Vacuum Extraction Units

## Industrial Vacuum Cleaner

### EUROSOG-I-D



EUROSOG-I-D

**ESTA PLUS**

#### Special Features

- » For continuous operation (DC version)
- » Manual brush cleaning mechanism for cleaning of the cartridge filter
- » Availability of cleanable cartridge filters for dust classifications M and H
- » Test certificates M and H available
- » Optionally available as ATEX version

#### Your Benefits

- » High suction force in dry dust
- » Low operating costs through the use of cleanable long life cartridge filters
- » Tilt-back filter housings for easy dust disposal
- » Small space requirement due to compact design
- » High mobility by smooth turning castors

Data dependent on equipment type

#### Application Range

- » Recommended for clean up work of coarse and fine dust



#### Ideal for

- Cotton dust
- Wood shavings
- Wood dust
- Metal dust
- Mineral dust
- Paper dust
- Tabacco fibres
- ... and many more



Gold Medal Award recipient from the Secretary of Economics for outstanding innovative achievements.



EUROSOG-I-D with floor nozzle for cleaning the shop

#### Technical Data

EUROSOG		-I-D
Max. volume flow	m <sup>3</sup> /h	260
Intake opening	mm	50
Max. negative pressure	Pa	19.500
Mains voltage	V	400
Nominal power	kW	2,2
Main filter surface	m <sup>2</sup>	2/5
Collection volume	l	80
Dimensions (L/W/H)	mm	1.030 × 670 × 1.240
Weight	kg	81
Sound pressure level	dB(A)	77

#### Order Number

EUROSOG-I-D/N (standard model)	<b>81.198</b>
EUROSOG-I-D/M with TÜV-test certificate for dust classification M	<b>81.399</b>
EUROSOG-I-D/H with TÜV-test certificate for dust classification H	<b>81.299</b>
EUROSOG-I-D ATEX version	<b>81.200</b>



## Industrial Vacuum Cleaner *DUROSOG-W*



DUROSOG-W

### Application Range

- » For sticky substances and dust that tends to clump
- » Cleaning of machines in factories and workshops
- » AC version for occasional use



### Ideal for

- Chemical dust
- Sticky dust
- Metal dust
- Paper dust
- Tabacco fibres
- ... and many more



DUROSOG-W for cleaning machines



The pre-separator container can be removed with one easy step. This is where the coarser dust and debris will be collected.

Easy disposal of the dust with a disposable paper filter bag.

**ESTA PLUS**

### Special Features

- » AC version for occasional use
- » Integrated pre-separator for rough dirt
- » Disposable paper filter bag
- » Test certificates for dust classification M and H available

### Your Benefits

- » With the use of special filtration technology this model is suitable for dry dust, sticky dust and dust that tends to clump
- » Convenient dust disposal in a paper filter bag
- » Small space requirement due to compact design
- » High mobility by smooth turning castors

Data dependent on equipment type

### Technical Data

DUROSOG		-W
Max. volume flow	m <sup>3</sup> /h	360
Intake opening	mm	50
Max. negative pressure	Pa	22.000
Mains voltage	V	230
Nominal power	kW	3 × 1.0
Main filter surface*	m <sup>2</sup>	3
Dust filter bag	l	70
Dimensions (L/W/H)	mm	660 × 630 × 950
Weight	kg	41
Sound pressure level	dB(A)	74

### Order Number

DUROSOG-W/N (Standard model)	<b>8024 N</b>
DUROSOG-W/M (Dust classification M)	<b>8024 M</b>
DUROSOG-W/H (Dust classification H)	<b>8024 H</b>

\* Filter only with certified model

Dust Extractors

High Vacuum Extraction Units

Welding Fume Filters

Oil Mist Separators

Carbon Filters / Air Purifier

Downdraft Tables

Extraction Fans

Extraction Arms

Filter Towers

Central Extraction Systems

Pipe Systems

About us

Interesting Information

# High Vacuum Extraction Units

## Industrial Vacuum Cleaner *DUROSOG-I-D*



DUROSOG-I-D

### Application Range

- » Three-phase powered industrial vacuum cleaner for defined continuous duty applications – ideal for sticky substances and dust that tends to clump
- » Fibres and shavings



### Ideal for

- Chemical dust
- Metal shavings
- Paper dust
- Tabacco fibres
- ... and many more



DUROSOG-I-D in operation

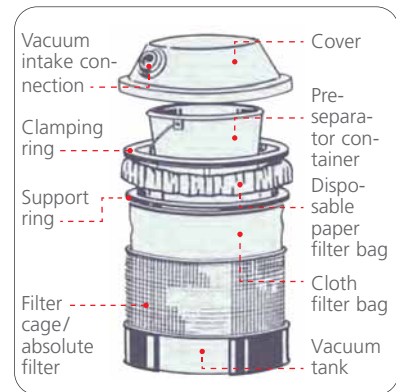

**ESTA PLUS**

### Special Features

- » For continuous operation (DC version)
- » Integrated pre-separator for rough dirt
- » Disposable paper filter bag
- » Test certificates for dust classification M, H and Zone 22\*\* available

### Your Benefits

- » With the use of special filtration technology this model is suitable for sticky dust and material that tends to clump
- » Convenient dust disposal in a paper filter bag
- » Small space requirement due to compact design
- » High mobility by smooth turning castors

Data dependent on equipment type

### Technical Data

DUROSOG		-I-D
Max. volume flow	m <sup>3</sup> /h	300
Intake opening	mm	50
Max. negative pressure	Pa	22.000
Mains voltage	V	400
Nominal power	kW	2.2
Main filter surface*	m <sup>2</sup>	3
Dust filter bag	l	70
Dimensions (L/W/H)	mm	850 × 630 × 950
Weight	kg	80
Sound pressure level	dB(A)	72

### Order Number

DUROSOG-I-D/N (Standard model)	<b>8120N</b>
DUROSOG-I-D/M (Dust classification M)	<b>8120M</b>
DUROSOG-I-D/H (Dust classification H)	<b>8120H</b>
DUROSOG-I-D ATEX	<b>8123</b>

\* Filter only with certified model

\*\* Suitable for vacuuming dry and flammable types of dust out of zone 22

## Industrial Vacuum Cleaners *WHISPERSOG*



High vacuum WHISPERSOG

### Application Range

- » Clean up work of coarse, fine and pourable types of dust
- » Direct extraction from manual processing machines and those in continuous operation
- » Connection to pipelines

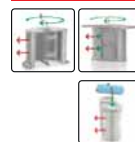

### Ideal for

- Cotton dust
- Plastic dust
- Mineral dust
- Paper dust
- Tabacco fibres
- ... and many more



The WHISPERSOG is suitable for many applications

### Special Features

- » For continuous operation (DC version)
- » Manual brush cleaning mechanism and pulse-jet filter cleaning system
- » Cleanable long life cartridge filters (Dust classification M)

### Your Benefits

- » Low-noise, high-performance vacuum cleaners for dry dust
- » Low operating costs through the use of cleanable long life cartridge filters
- » Tilt-back filter housings for easy dust disposal
- » Small space requirement due to compact design
- » High mobility by smooth turning castors

Data dependent on equipment type

### Technical Data

WHISPERSOG		2,2	3,0
Max. volume flow	m <sup>3</sup> /h	300	216
Intake opening	mm	50	50
Max. negative pressure	Pa	21.000	31.500
Mains voltage	V	400	400
Nominal power	kW	2.2	3.0
Main filter surface	m <sup>2</sup>	2	2
Collection volume	l	80	80
Dimensions (L/W/H) (Manual filter cleaning)	mm	1.300 × 640 × 1.250	1.300 × 640 × 1.250
Weight	kg	105	120
Sound pressure level	dB(A)	73	75

### Order Number

Manual filter cleaning system	<b>83.101</b>	<b>83.102</b>
Pulse-jet-cleaning	<b>83.113</b>	-

# High Vacuum Extraction Units

## Central Vacuum Cleaner *CENTRASOG CVS 2.0*



CENTRASOG CVS 2.0

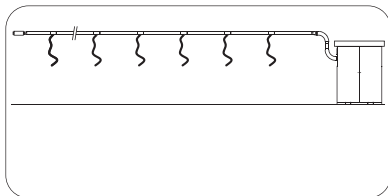

CENTRASOG CVS 2.0 at a central conduit

### Application Range

- » Central high vacuum dust extraction system for industrial and handicraft enterprises
- » Machines and workplace cleaning
- » Connecting of portable hand held machine tools
- » In special design as a central vacuum system for car interior cleaning at car wash



### Ideal for

- Plastic dust
- Metal dust
- Dirt and shavings
- ... and many more

### Special Versions

- » Custom paint finish
- » Variation for car interior cleaning
- » Weather-resistant housing for outdoor installation



Simple car interior cleaning at multiple extraction points



Weather-resistant housing for outdoor installation

**ESTA PLUS**

### Special Features

- » High performance side channel blowers – for maximum suction capacity
- » Fully assembled, immediately ready for use
- » Two-stage filter system with integrated cyclone pre-separator and filter cartridge of dust class M

### Your Benefits

- » Low operating costs with cleanable long life filter cartridges
- » Compact and user friendly design
- » Low operating noise through sound-insulated housing

Data dependent on equipment type

### Technical Data

CENTRASOG CVS 2.0		8	12	15
Max. volume flow	m <sup>3</sup> /h	700	1.000	1.950
Intake opening	mm	160	160	160
Max. negative pressure	Pa	19.000	18.000	13.000
Mains voltage	V	400	400	400
Nominal power	kW	8.5	12.5	15.0
Max sucking station	Ø36/50 mm	6/3	10/6	15/9
Main filter surface	m <sup>2</sup>	16.0	16.0	16.0
Collection volume	l	200	200	200
Dimensions (L/W/H)	mm	2.170 × 1.078 × 2.433		
Weight	kg	840	900	950
Sound pressure level	dB(A)	78	78	78
<b>Order Number</b>		<b>87.500</b>	<b>87.600</b>	<b>87.700</b>

## Wet and dry vacuum *MULTISOG-1 and -4*



MULTISOG-1



MULTISOG-4

### Application Range

- » Clean up work in office and work areas
- » Suitable for dust, dirt and liquids



### Ideal for

- Dust
- Dirt
- Liquids
- ... and many more



MULTISOG for use via drill press

**ESTA PLUS**

### Special Features

- » Three power levels, depending on the application
- » Paper filter bags
- » Fabric filter
- » Mechanical liquid shut off device
- » Stainless steel boiler (Multisog-4)

### Your Benefits

- » Suitable for dust, dirt and liquids
- » Small space requirement due to compact design
- » Easy disposal of the collected dust

Data dependent on equipment type

### Technical Data

MULTISOG		-1	-4
Max. volume flow	m <sup>3</sup> /h	215	250
Intake opening	mm	36	50
Max. negative pressure	Pa	21.000	20.500
Mains voltage	V	230	230
Nominal power	kW	1.2	1.5
Collection volume	l	35	35
Dimensions (L/W/H)	mm	500 × 500 × 840	600 × 500 × 900
Weight	kg	13	25
Sound pressure level	dB(A)	67	62
<b>Order Number</b>		<b>4622</b>	<b>4533</b>

Dust Extractors

High Vacuum Extraction Units

Welding Fume Filters

Oil Mist Separators

Carbon Filters / Air Purifier

Downdraft Tables

Extraction Fans

Extraction Arms

Filter Towers

Central Extraction Systems

Pipe Systems

About us

Interesting Information

# High Vacuum Extraction Units

## Pre-separator Systems for Industrial Vacuum Cleaners and/or mobile Extractors

### Which pre-separator should be used for which application?

Dry	Wet	Light material and dust
<p>Heavy, coarse substances and larger quantities of dust.</p>	<p>Materials that are soaked in liquid (Metal shavings and coarse particles, etc.) will be collected in a strainer basket, while the liquid drains down into a collection container that can be emptied through a drain valve.</p>	<p>Large quantities of light materials and dust should be collected in a disposable paper filter bag.</p>
Scope of delievery	Scope of delievery	Scope of delievery
<p>Wheel base, pre-separator container with plastic bag insert, cover with intake and outlet connection to the vacuum.</p>	<p>Wheel base, pre-separator container and strainer basket, cover with float valve and intake and outlet connection to the vacuum.</p>	<p>Wheel base, pre-separator container with hose connection on the side, filter cage and cloth filter bag for inserting disposable paper filter bags and connection to the vacuum cleaner.</p>
<p><b>Pre-separator TR 1</b> with 100 liter container <b>Order-Number: 1100</b></p>	<p><b>Pre-separator NA 1</b> with 100 liter container <b>Order-Number: 1102</b></p>	<p><b>Pre-separator ST 1</b> with 100 liter container <b>Order-Number: 1103</b></p>
<p><b>Pre-separator TR 2</b> with 200 liter container <b>Order-Number: 1200</b></p>	<p><b>Pre-separator NA 2</b> with 200 liter container <b>Order-Number: 1202</b></p>	<p><b>Pre-separator ST 2</b> with 200 liter container <b>Order-Number: 1203</b></p>

#### Your Benefits

- » The ideal complement for industrial vacuums for applications With solid dry and wet dust types as well as large quantities of shavings

Data dependent on equipment type

For precise capture and extraction of welding smoke

SRF K-10/K-15

MOBEX F

SRF T-2/T-4

DUSTMAC F

DUSTOMAT DRY



## Application Range

Welding of:

- » Aluminum
- » Construction steel
- » Coated sheet metal
- » Galvanized parts
- » Stainless steel  
(Chrome-Nickel, etc.)

- » Direct extraction at the welding torch
- » Soldering
- » Workplace ventilation
- » etc.

## Test certificates



IFA 1205007

Gefahrstoffgeprüft  
Schweißrauch-  
abscheideklasse W3



IFA 1105037

Gefahrstoffgeprüft  
Schweißrauch-  
abscheideklasse W3



IFA 1405011

Gefahrstoffgeprüft  
Schweißrauch-  
abscheideklasse W2

Dust Extractors

High Vacuum  
Extraction Units

Welding Fume  
Filters

Oil Mist  
Separators

Carbon Filters/  
Air Purifier

Downdraft  
Tables

Extraction Fans

Extraction Arms

Filter Towers

Central Extraction  
Systems

Pipe Systems

About us

Interesting  
Information

# Welding Fume Filters

## Introduction and Product overview

### Introduction

Welding produces toxic fumes that can be captured and effectively eliminated by a welding fume filter.

Filtering is done directly through a nozzle or extraction hood. The filtered air is routed back into the work area or outdoors through a pipeline.

For extracting welding fumes, ESTA offers mobile, portable and stationary extraction solutions custom made to the application. For extracting welding fumes from high-alloy steels, ESTA welding fume filters are optionally available with IFA W2 and W3 certificates.

### Product overview

**SRF K** series devices are good for mobile welding fume extraction at one or two workstations. Their compact design makes them easy to transport to their place of use. High suction performance allows welding fume extraction over a long distance, making work easier.

**ESTA extraction arms** with specially designed extraction hoods are used to capture the fumes.

The **SRF T** appliances are compact, portable welding fume filters that capture welding fumes directly at source, ie from welding torches.

The compact welding fume filters of the **DUSTOMAT DRY**-series are suitable for almost all purposes thanks to their versatile configurations, and, among other things, effectively extract the welding and soldering fumes generated during the processing of different metals (separation efficiency of up to 99.995 %).

Thanks to aerodynamic optimisation, the welding fume filters of the DUSTOMAT DRY series have even higher energy efficiency compared to their predecessors. The innovative filter cleaning system also offers users significant savings potential: thanks to compressed air savings of up to 50 percent and extended filter service life, follow-up costs are reduced to a minimum.



For optimum fume capturing at up to four extraction points, or for small welding booths, ESTA offers the stationary welding fume filters in the **MOBEX F**-series. The 'entry-level' models in the stationary series are suitable for use with airflows of up to 4500 m<sup>3</sup> per hour.

The systems of the **DUSTMAC F**-series have a modular structure and can therefore be used as welding fume filter systems for any required air volume be combined.



## Mobile Welding Fume Filter *SRF K-10*



Mobile welding fume filter SRF K-10

### Application Range

- » Extraction during welding of all metals
- » Intermittent and continuous duty operation
- » Optional: soldering fume extraction



Test certificates (optional)



### Special Versions

- » IFA Test Certificate W3 for high-alloy metals
- » Special voltage
- » Activated carbon filter



SRF K-10 in operation

### Special Features

- » Cleanable long life cartridge filters (Dust classification M)
- » Filter cleaning with compressed air gun or rotary cleaning (manually)
- » Dust-free disposal of separated smoke particles

### Your Benefits

- » Powerful capturing of the welding fumes
- » Mobile for versatile use and suitable for continuous duty applications
- » Compact and user friendly design
- » Low operating costs through the use of cleanable long life cartridge filters
- » Convenient disposal of the dust

Data dependent on equipment type

### Technical Data

Welding fume filter model SRF		K-10
Max. volume flow	m <sup>3</sup> /h	950
Intake opening	mm	140
Max. negative pressure	Pa	2,800
Nominal power	V/kW	230 / 1.3
Main filter surface	m <sup>2</sup>	10
Dimensions (L/W/H)	mm	946 × 761 × 1,361
Weight	kg	69
Sound pressure level	dB(A)	72
Order Number		
Standard		55.203
Standard with IFA „W3“ Test. Cert.		55.235
Man. operated rotating filter cleaning		70 268 130

IFA\*) = German Institute for Occupational Health and Safety

# Welding Fume Filters

## Mobile Welding Fume Filter SRF K-15



Mobile welding fume filter SRF K-15

### Application Range

- » Extraction during welding of all metals
- » Intermittent and continuous duty operation
- » A mobile device for two extraction points or for connection to pipe systems
- » Optional: soldering fume extraction

### Special Versions

- » IFA Test Certificate W3 for high-alloy metals
- » Special voltage
- » Activated carbon filter
- » Exhaust air connection



Test certificates (optional)



SRF K-15 with pipe system

**ESTA PLUS**

### Special Features

- » Filter cleaning with compressed air gun or rotary cleaning (manually)
- » Cleanable long life cartridge filters (Dust classification M)

### Your Benefits

- » High performance smoke capture at two extraction locations
- » Mobile for versatile use and suitable for continuous duty applications
- » Compact and user friendly design
- » Low operating costs through cleanable cartridge filters
- » Dust-free disposal of the separated smoke particles

Data dependent on equipment type

### Technical Data

Welding fume filter model SRF		K-15
Max. volume flow	m <sup>3</sup> /h	1,500
Intake opening	mm	2 × 140
Max. negative pressure	Pa	2,500
Motor Power	V/kW	400 / 2.2
Main filter surface	m <sup>2</sup>	15
Dimensions (L/W/H)	mm	946 × 761 × 1,361
Weight	kg	74
Sound pressure level	dB(A)	77
Order Number		
Standard		55.212
Standard with IFA „W3“ Test. cert.		55.229
Man. operated rotating filter cleaning		70 269 130

IFA\*) = German Institute for Occupational Health and Safety

## Mobile Welding Fume Filter *SRF K-10 / SRF K-15*



Patented ESTA tilt mechanism



Convenient disposal of the dust

### Accessories and Attachments SRF K-10 / SRF K-15

#### Wall Console



Metal bracket for wall mounting of the welding fume filter.

	Order Number
SRF K-10	60400001
SRF K-15	60400001

- Dust Extractors
- High Vacuum Extraction Units
- Welding Fume Filters**
- Oil Mist Separators
- Carbon Filters/ Air Purifier
- Downdraft Tables
- Extraction Fans
- Extraction Arms
- Filter Towers
- Central Extraction Systems
- Pipe Systems
- About us
- Interesting Information

# Welding Fume Filters

## Portable Welding Fume Filter

### SRF T-2 / SRF T-4



Portable welding fume filter SRF T-2



SRF T-4, a mobile device for two extraction points or for connection to pipe systems

#### Application Range

- » For the direct extraction at the welding torch
- » Outside work, assembly or construction sites
- » Non-alloy steels and steel with low alloy content

#### Special Versions

- » Exhaust air connection
- » Special voltage
- » IFA Test Certificates W3 (SRF T-2) for high-alloy metals
- » Custom paint finish



Test certificates (optional)

W3



SRFT-2

Gefahrstoffgeprüft  
Schweißrauch-  
abscheideklasse W3



SRF T-2, direct extraction from one welding torch

#### Accessories



Slotted nozzle. Order Number 94.741



Cone shaped nozzle. Order Number 94.740

#### Special Features

- » Powerful suction turbine
- » Integrated compressed air cleaning nozzle
- » Cleanable long life cartridge filters (Dust classification M)
- » Direct extraction of welding torches or nozzles

#### Your Benefits

- » High performance direct extraction of welding torches or nozzles
- » Portable units that can be used in any location
- » Compact and functional design
- » Low operating costs with cleanable long life cartridge filters

Data dependent on equipment type

#### Technical Data

Welding fume filter model SRF		T-2*	T-4
Max. volume flow	m <sup>3</sup> /h	200	400
Intake opening	mm	50	2 × 50
Max. negative pressure	Pa	19.000	19.000
Mains voltage	V	230	230
Nominal power	kW	1.1	2.2
Main filter surface	m <sup>2</sup>	0,8	1,6
Dimensions (L/W/H)	mm	390 × 210 × 500	490 × 400 × 560
Weight	kg	15	27
Sound pressure level	dB(A)	66	78
<b>Order Number</b>		<b>55.101</b>	<b>55.102</b>

\* available in W3-tested Version

## Mobile welding fume filter *DUSTOMAT DRY*



DUSTOMAT DRY

### Application Range

- » Single or multiple user extraction of welding fumes
- » Welding of all metals
- » Depending on the version, also suitable for carcinogenic welding fumes
- » For direct extraction on processing machines and welding robots
- » For connection to extraction arms, extraction tables, extraction hoods and shorter pipe systems



Test certificates (optional)

W3

### Special models

- » Pre-separator for sparks, chips and dusts
- » HEPA H 14 filter (separation efficiency  $\geq 99.995\%$ )
- » Downstream activated carbon filter for odour neutralisation
- » Version with frequency converter
- » Stationary version
- » Version with exhaust air connection piece
- » Variable positioning of intake connection piece, touch display, control cabinet, etc.
- » Other versions on request

### Special features

- » Suitable for medium performance ranges from 2,000 to 3,500 m<sup>3</sup>/h
- » Available in four output levels
- » Variable cleaning system, depending on the application
- » 50 % compressed air savings thanks to innovative jet pulse filter cleaning system
- » Integrated impact separator for pre-separation of coarse and heavy particles

### Your Benefits

- » Configurable: extraction power, filter package and system design
- » Strong extraction power for optimal extraction results
- » Aerodynamically optimised design for efficient air flow, resulting in low operating costs
- » Low-noise system operation
- » Recirculation/exhaust air operation possible
- » Smooth-running castors
- » Compact design
- » Mobile dust collection drawer for easy disposal
- » Sturdy, durable steel construction
- » Intuitive operation via a convenient touch display
- » High level of operation and maintenance friendliness

Data depending on model version

### Technical Data

DUSTOMAT DRY		2000	2700	3300	3500
Max. volume flow	m <sup>3</sup> /h	2.000	2.700	3.100	3.500
Max. negative pressure	Pa	2.400	2.900	3.400	4.500
Intake opening	mm	160	180	200	200
Mains voltage	V	400	400	400	400
Nominal power	kW	2,2	3,0	4,0	5,5
Circuit breaker	A	C16	C16	C16	C16
Compressed air connection	Inch	¾"	¾"	¼"	¼"
Main filter quantity	Piece	2	2	2	2
Main filter surface	m <sup>2</sup>	10	10	20	20
Collection volume	l	50	50	50	50
Dimensions (L/W/H)	mm	1.630	1.630	1.630	1.630
		× 840	× 840	× 840	× 840
		× 1.430	× 1.430	× 1.680	× 1.680
Weight	kg	300	300	330	330
Sound pressure Level	dB(A)	66	68	71,5	75
<b>Order Number</b>					
Standard		<b>X09700</b>	<b>X09701</b>	<b>X09702</b>	<b>X09703</b>

# Welding Fume Filters

## Stationary Welding Fume Filters

### MOBEX F



MOBEX F-40

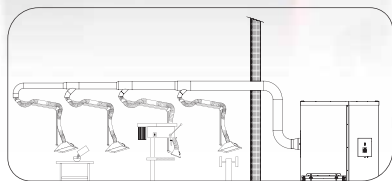

With a pipe system or a hose, the MOBEX series can be connected to processing machines for direct extraction

#### Application Range

- » Single- or multi-extraction of welding fumes
- » Welding of all metals
- » Extraction of robot welding booths



Test certificates (optional)



W3



Product-Video

#### Special Versions/Accessories

- » Available in a IFA-W3-tested version for extracting welding fumes from high-alloy steel
- » Special voltage
- » Exhaust air connection
- » Pipe pre-separator
- » Spark pre-separator
- » Extinguishing device



MOBEX F-60 with extraction arm

#### Technical Data

MOBEX		F-40	F-60	F-80
Max. volume flow	m <sup>3</sup> /h	2.800	4.500	5.600
Intake opening	mm	224	280	300
Max. negative pressure	Pa	3.400	3.400	3.300
Mains voltage	V	400	400	400
Nominal power	kW	3,0	4,0	4,0*
Main filter quantity	Piece	2	3	4
Main filter surface	m <sup>2</sup>	28	42	56
Collection volume	l	100 – 150 (2 × 38**)	100 – 150 (2 × 38**)	100 – 150 (2 × 38**)
Dimensions (L/W/H)	mm	1.910 × 1.040 × 2.030***	2.030 × 1.040 × 2.030***	2.030 × 1.040 × 2.030***
Weight	kg	310	350	415
Sound pressure level	dB(A)	71	74	77
<b>Order Number</b>				
Standard		<b>09.837</b>	<b>09.838</b>	–
With spark pre-separator		<b>09.837 FA</b>	<b>09.838 FA</b>	<b>09.853 FA</b>
With test certificate W3		<b>09.835</b>	<b>09.836</b>	–
<b>eco<sup>+</sup></b>		<b>09.848</b>	<b>09.849</b>	<b>09.853</b>

\* Other impeller \*\* with dust collection box \*\*\* without spark trap

**ESTAPLUS**

#### Special Features

- » A new sandwich-panel housing design
- » Pulse-jet filter cleaning
- » Integrated impact separator

#### Your Benefits

- » Low operating costs thanks to cleanable permanent filter (Dust classification M)
- » Long filter life due to a pre-separation system
- » Low operating noise thanks to a sound-insulated housing
- » Minimal space requirements
- » Easy, dust-free removal of collected material through a new disposal system

## Stationary Welding Fume Filters *MOBEX F*

**ESTA Control** is a newly-developed device control that ensures energy-efficient device operation with state-of-the-art sensor technology. **Power savings of up to 50%** compared to conventional differential pressure controls are obtained through current volume flow measurement and the fully-automated regulation of the extraction performance based on the operating parameters.



Dust Extractors

High Vacuum  
Extraction Units

Welding Fume  
Filters

Oil Mist  
Separators

Carbon Filters/  
Air Purifier

Downdraft  
Tables

Extraction Fans

Extraction Arms

Filter Towers

Central Extraction  
Systems

Pipe Systems

About us

Interesting  
Information

# Welding Fume Filters

## Modular Welding Fume Extraction System *DUSTMAC F*



DUSTMAC F

### Application Range

- » Central systems with multiple extraction locations
- » Large extraction hoods or cells, e.g. robotic welding stations
- » All types of steel



Test certificates (optional)



### Special Versions

- » IFA-Test Certificate W3 for high-alloy metals
- » Pipe pre-separator
- » ATEX-version
- » **Special Control cabinet series**
- » Custom paint finish



Central welding fume extraction system DUSTMAC F in the chemical industry

**ESTA PLUS**

### Special Features

- » Control cabinet series Basic or Comfort
- » Pulse-jet filter cleaning system
- » Cleanable long life cartridge filters (Dust classification M)

### Your Benefits

- » High performance welding fume extraction from multiple locations, from welding cells or from large extraction hoods
- » Customer specific design of the system
- » Modular for future expansion
- » Low operating costs with cleanable long life filter cartridges

Data dependent on equipment type

### Technical Data

DUSTMAC		F-42	F-84	F-84	F-126	F-189
Max. volume flow	m <sup>3</sup> /h	3.500	7.800	9.700	10.300	14.000
Intake/outlet diameter	mm	224/300	280/400	315/450	355/500	450/560
Max. negative pressure	Pa	2.600	3.800	3.800	4.400	4.800
Mains voltage	V	400	400	400	400	400
Nominal power	kW	3.0	5.5	7.5	11.0	15.0
Main filter surface	m <sup>2</sup>	42	84	84	126	189
Main filter quantity	Pieces	2	4	4	6	9
Collection volume	l	50	50	50	50	50
Dimensions (L/W/H)	mm	1.300 × 1.039 × 3.250	1.400 × 1.350 × 3.410	1.400 × 1.350 × 3.410	1.820 × 1.450 × 3.860	1.850 × 1.900 × 3.910
Weight	kg	440	540	540	740	880
<b>Order Number</b>		<b>663.042</b>	<b>663.084</b>	<b>663.085</b>	<b>663.126</b>	<b>663.189</b>



## Extraction of Oil and Emulsion Mist

- OILMAC 400
- OILMAC 800
- OILMAC 1600
- OILMAC 3000



### Application Range

- » Aircraft construction
- » Machine building industry
- » Metal construction and processing industry
- » Shipbuilding industry
- » Vehicle construction

- Dust Extractors
- High Vacuum Extraction Units
- Welding Fume Filters
- Oil Mist Separators**
- Carbon Filters/ Air Purifier
- Downdraft Tables
- Extraction Fans
- Extraction Arms
- Filter Towers
- Central Extraction Systems
- Pipe Systems
- About us
- Interesting Information

# Oil Mist Separators

## Oil Mist Separators OILMAC



Oil Mist Separator OILMAC 800

### Application Range

- » Extraction of oil and emulsion mist, minimal lubricant mist and smoke
- » For set-up and attachment to CNC machines

### Special features/Accessories

- » Special voltage
- » Exhaust air outlet
- » Special painting
- » Chassis (OILMAC 800/1600)



### Ideal for

Aerosols

Fumes

Mist particles



Product-Video



Pivoting fan module



Pivoting inlet module



OILMAC 800 on a universal lathe

**ESTAPLUS**

### Special Features

- » Patented housing design allows filter replacement without tools
- » Manual cleaning
- » Mechanical filtration
- » Also available as a filter unit, without fan

### Your Benefits

- » Easy attachment to the machine
- » Available in four performance levels
- » Compact shape
- » Multiple filter system for high filtration efficiency
- » Filter replacement and maintenance without tools

### Technical Data

OILMAC		400	800	1600	3000
Max. volume flow	m <sup>3</sup> /h	420	840	1800	3300
Intake opening	mm	150	200	250	300
Mains voltage	V	230	400	400	400
Nominal power	kW	0,24	0.55	1.1	2.2
Dimensions (L/W/H)	mm	640 x 650 x 510	1.140 x 685 x 475	1.270 x 685 x 805	1.790 x 650 x 1.265
Weight	kg	50	80	130	220
Sound pressure level	dB(A)	66	69	71	74
<b>Order Number</b>					
Design with HEPA-filter		<b>56.200</b>	<b>56.201</b>	<b>56.202</b>	<b>56.203</b>
Design with Backup filter made of metal mesh		–	<b>56.211</b>	<b>56.212</b>	<b>56.213</b>
Filter unit without fan		–	<b>56.221</b>	<b>56.222</b>	<b>56.223</b>

All devices include a 5.0m siphon hose

## How the three-stage filter system works

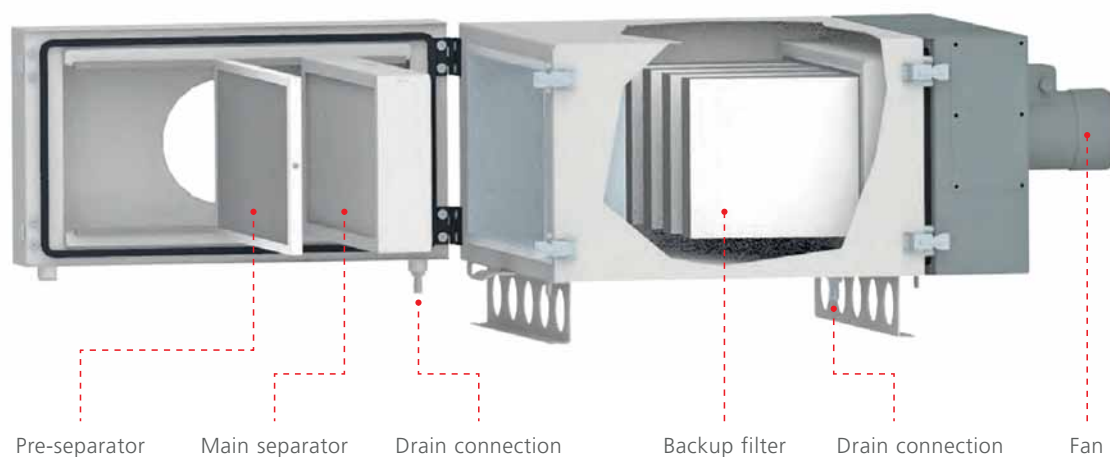

### Pre-separator

A wear-free, cleanable metal mesh filter already separates most solid and coarse particles.

### Main separator

A filter cassette F9 acts like a depth filter. Separated aerosols can drain while the separated particles remain in the filter material. The draining of aerosols is supported by gravitational force and two siphon connections.

### Backup filter

Remaining aerosols are retained by a HEPA H13 filter with a filtration efficiency of 99.95% allowing for recirculation of air. Alternatively, a knitted mesh filter can be used as backup filter.



# Carbon Filters/Air purifier

Compact device with activated carbon for filtering out odors and gaseous pollutants

---

## ActiveBox®

---

Compact device for filtering odors and slight chemical exposure

---

## TowerBox®

---

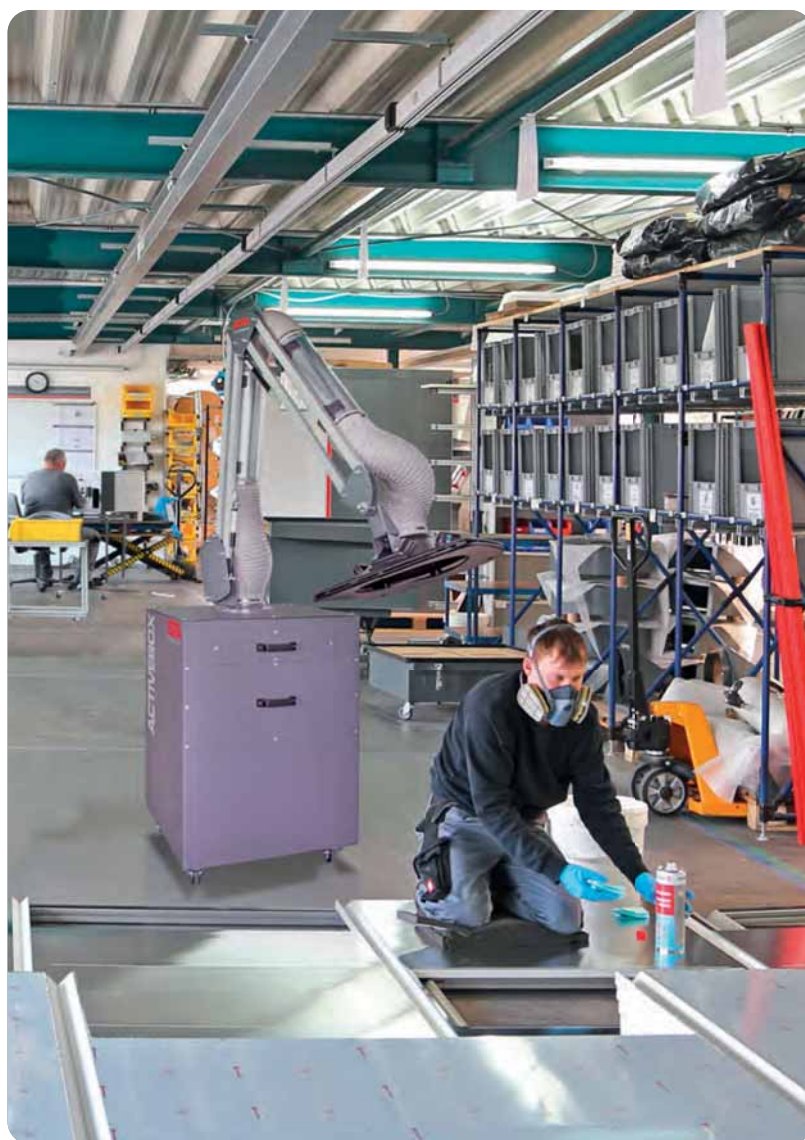

---

### **Application Range**

- » Metal processing industry
- » Plastics industry
- » Chemical industry
- » Pharmaceutical industry
- » Automotive industry
- » Textile, leather and clothing industry

---

### **Application Range**

- » Medical practices
- » Meeting rooms
- » Pubs / restaurants
- » Hair salons
- » Gyms
- » Beverage markets
- » Open plan offices
- » Classroom
- » Supermarkets
- » Waiting areas

## Carbon filter *ActiveBox®*



### Application range

- » Stand-alone extraction with at-source collection in industry and trade
- » Suitable for gaseous environmental pollutants and to reduce unpleasant and/or process-related odours



### Ideal for

Gaseous odor and pollutants

Minor chemical cal loads

... and many more



**ESTAPLUS**

### Special Features

- » Rotatable, flexible extraction arm for mounting on the device
- » Flow-optimised and patented extraction hood
- » Operating hours counter
- » G4 pre-filter for a longer service life of the activated charcoal cartridges

### Your Benefits

- » Efficient process air collection
- » Mobile use and suitable for continuous operation
- » Compact and handy design
- » Activated charcoal cartridges (type A) for good flow behaviour and handling of the activated charcoal
- » Quiet and energy-saving operation thanks to EC technology

Data dependent on equipment type

### Technical data

		ActiveBox®
Max. volume flow	m³/h	1.000
Intake opening	mm	140
Mains voltage	V	230
Rated frequency	Hz	50/60
Rated current	A	2,2
Circuit breaker	A	16
Nominal frequency	kW	0,51
Filter area	m²	1,21
Main filter quantity	Units	1 (G4 Pre-filter)
Activated carbon volume	l	24
Activated carbon cartridges	Units	6
Dimensions (L/W/H)	mm	692 × 660 × 960 <sup>1)</sup> 2.223 × 660 × 1.910 <sup>2)</sup>
Weight	kg (ca.)	100
Sound pressure level	dB(A)	68
<b>Order-No.</b>		<b>555.06</b>

<sup>1)</sup> Without extracton arm / <sup>2)</sup> With extracton arm

Dust Extractors

High Vacuum  
Extraction Units

Welding Fume  
Filters

Oil Mist  
Separators

Carbon Filters/  
Air Purifier

Downdraft  
Tables

Extraction Fans

Extraction Arms

Filter Towers

Central Extraction  
Systems

Pipe Systems

About us

Interesting  
Information

# Carbon Filters/Air purifier

## Air purifier TowerBox®



### Application range

- » Room air extraction for welding fumes and airborne dusts in industry and trade
- » Supplementary solution to at-source extraction



### Ideal for

- Welding fume
- Particulate matter
- ... and many more



## ESTA PLUS

### Special Features

- » Perforated tube on the top of the device for uncomplicated and optimal collection
- » Operating hours counter

### Your Benefits

- » Efficient fumes collection to improve room air quality
- » Mobile use and suitable for continuous operation
- » Compact and handy design, also suitable for use in confined areas
- » Simple and dust-free disposal of the collected material through a drawer
- » Dust class M Filter cartridge
- » Quiet and energy-saving operation thanks to EC technology

Data dependent on equipment type

### Technical Data

		TowerBox®
Max. volume flow	cfm	950
Intake opening	mm	140
Mains voltage	V	230
Nominal frequency	Hz	50/60
Nominal current	A	2.2
Circuit breaker	A	16
Nominal power	HP	0.51
Main filter surface	m <sup>2</sup>	13.57
Main filter quantity	Piece	3
Dimensions (L/W/H)	mm	692 × 660 × 959 <sup>1)</sup> 692 × 660 × 1,973 <sup>2)</sup>
Weight	kg (ca.)	100
Sound pressure level	dB(A)	53* (70.5)
<b>Order Number</b>		<b>555.04</b>

<sup>1)</sup> Without pipe / <sup>2)</sup> With pipe / \*With optional sound insulation package

Welding/Grinding Downdraft Tables  
for connection to a mobile or stationary extraction system

TableBox® Air

TableBox® Active

A 880 to A 2080

360°-Suction-Table

Plasma-cutting Table



#### **Application Range**

- » Aircraft construction
- » Automobile industry
- » Machine building industry
- » Metal industry
- » Plastics industry
- » Shipbuilding industry
- » Stone Industry
- » Vehicle construction

Dust Extractors

High Vacuum  
Extraction Units

Welding Fume  
Filters

Oil Mist  
Separators

Carbon Filters/  
Air Purifier

**Downdraft  
Tables**

Extraction Fans

Extraction Arms

Filter Towers

Central Extraction  
Systems

Pipe Systems

About us

Interesting  
Information

# Downdraft Tables

## Welding/Grinding Downdraft Table

### TableBox® Air / TableBox® Active



#### Areas of application

- » Single-place extraction in industry and trade
- » Suitable for welding fumes, free-flowing and dry dust

#### Optional

- » Lighting
- » Exhaust silencer



#### Ideal for

- Metal dust
- Welding fume
- Plastic shavings
- Fumes
- CRP-/GRP-dusts
- Smoke
- Mineral dusts
- Concrete dust
- Gaseous odors and pollutants
- Minor chemical loads
- ... and many more



TableBox® Air with support grid



Rear-/side wall with LED-Lamp

**ESTAPLUS**

#### Special Features

- » Stepless adjustment of the air volume flow
- » G4 pre-filter for a longer service life of the activated carbon cartridges
- » Operating hours counter

#### Your Benefits

- » Efficient process air collection
- » Mobile use and suitable for continuous operation
- » Compact and easy-to-handle design
- » Activated charcoal cartridges (type A) for good flow behavior and handling of the activated charcoal
- » A drawer enables simple and dust-free disposal of the collected material
- » Filter cartridge with dust class M
- » Quiet and energy-saving operation thanks to EC technology

Data depending on model version

#### Technical Data

		TableBox® Air	TableBox® Active
Max. volume flow	cfm	1.300	950
Intake opening	mm	140	140
Mains voltage	V	230	230
Nominal frequency	Hz	50/60	50/60
Nominal current	A	2,2	2,2
Circuit breaker	A	16	16
Nominal power	HP	0,51	0,51
Main filter surface	m <sup>2</sup>	13,57	1,2
Main filter quantity	Piece	3	1 (G4 Prefilter)
Activated carbon volume	l	–	24
Activated carbon cartridges	Quantity	–	6
Dimensions (L/W/H)	mm	692 × 681 × 1.009	692 × 681 × 1.009
Weight	kg (ca.)	110	105
Sound pressure level	dB(A)	60.5* (69,9)	60.5* (68,5)
<b>Order Number</b>		<b>55507</b>	<b>55508</b>

\* With optional sound insulation package



## Welding/Grinding Downdraft Tables *Series A*



Worktable for welding and grinding

### Application Range

- » For connection to ventilator or extraction system
- » Working table for welding, grinding, deburring of all types of metals
- » Also suitable for other applications (e.g. plastics processing, gluing processes)



### Ideal for

- Metal dust
- Welding fume
- Plastic shavings
- Fumes
- CRP-/GRP-dusts
- Stone dust

... and many more



Welding table with side panels and back wall



Integrated coarse dirt collecting drawer



Side panel swung back for larger work pieces

**ESTAPLUS**

### Special Features

- » Galvanized grid
- » Height adjustable ( $\pm 100$  mm)
- » Drawer for coarse dirt
- » Variable connection piece (right or left)

### Your Benefits

- » Extraction directly at the workstation
- » Compact solution
- » Plenty of knee and leg room
- » A stable steel plate housing
- » For variable use
- » Easy disposal of coarse dirt

Data depending on model version



Dust Extractors

High Vacuum Extraction Units

Welding Fume Filters

Oil Mist Separators

Carbon Filters/Air Purifier

Downdraft Tables

Extraction Fans

Extraction Arms

Filter Towers

Central Extraction Systems

Pipe Systems

About us

Interesting Information

# Downdraft Tables

## Welding/Grinding Downdraft Tables

### Series A



#### Special Versions/Accessories

- » Side panels
- » Rear wall extraction
- » Lid for optimal airflow
- » Lighting installed in the cover
- » Mobile unit on casters
- » Version with steel T-grate, fiberglass or wood slat grate
- » Customer specific dimensions available
- » Rotary disk for placement on grate
- » Reinforcement plate for fastening a vice



#### Technical Data

<b>Welding and Grinding Table</b> without extraction fan		<b>A 880</b>	<b>A 1280</b>	<b>A 1680</b>	<b>A 2080</b>
Working surface (L/W)	mm	800 x 700	1.200 x 700	1.600 x 700	2.000 x 700
Intake diameter	mm	160	160	200	200
Dimensions (L/W/H)	mm	880 x 840 x 800	1.280 x 840 x 800	1.680 x 840 x 800	2.080 x 840 x 800
Dimensions (L/W/H)	mm	880 x 840 x 1.600	1.280 x 840 x 1.600	1.680 x 840 x 1.600	2.080 x 840 x 1.600
<b>Order Number</b>					
Standard		<b>44.010</b>	<b>44.020</b>	<b>44.030</b>	<b>44.040</b>
with side panels		<b>44.011</b>	<b>44.021</b>	<b>44.031</b>	<b>44.041</b>
with side panels and back wall extraction		<b>44.012</b>	<b>44.022</b>	<b>44.032</b>	<b>44.042</b>

## Welding and grinding tables *360°-suction table*



### Areas of application

- » For connection to a fan or extraction system
- » For grinding, welding and deburring of metal parts
- » Can be used for further applications

### Special version / accessories

- » Lighting
- » Individual pedestal
- » Optimum, infinitely variable electrical height adjustment
- » ATEX compliant
- » Hood
- » Unit support



### Ideal for

- Metal dust
- Welding fume
- Chipped plastics
- Fumes
- CFK-/GFK dust
- Mineral dust
- Concrete dust
- ... and many more

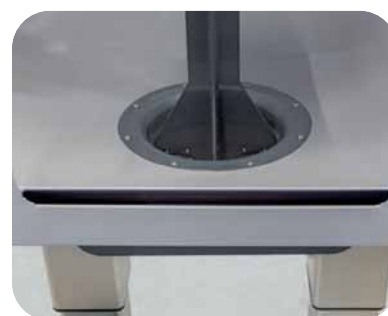

Suction nozzle in front area

**ESTAPLUS**

### Special features

- » Workpiece accessible from all sides (360°)
- » Maximum workpiece width: 900 mm (with closed walls)
- » Height adjustment: 980 to 1,180 mm
- » Requires approx. 2,500 m³/h air volume
- » Suction nozzle in front area
- » Adjustable end stop
- » Vice
- » Foldable side panelling

### Benefits for you

- » More efficiency when machining workpieces
- » Time saving due to fewer transformer steps and process shortening due to shorter cycle times
- » Highest levels of ergonomics for employees
- » Less contamination of the workplace
- » Optimised occupational health and safety

Data depending on model version

### Standard-Extraction table



1<sup>st</sup> clamping



2<sup>nd</sup> clamping



3<sup>rd</sup> clamping



4<sup>th</sup> clamping



### 360°-Extraction table



**Only clamp once!**



### Technical data

360°-suction table		
Connection diameter	mm	250
Dimensions (W/H/D) without hood	mm	1,000 × 1,140 × 970
Dimensions (W/H/D) with hood	mm	1,000 × 1,400 × 970
Weight	kg	160
<b>Order No.</b>		<b>44050</b>

Dust Extractors

High Vacuum  
Extraction Units

Welding Fume  
Filters

Oil Mist  
Separators

Carbon Filters/  
Air Purifier

Downdraft  
Tables

Extraction Fans

Extraction Arms

Filter Towers

Central Extraction  
Systems

Pipe Systems

About us

Interesting  
Information

# Downdraft Tables

## Welding and grinding tables *Plasma-cutting Table*



### Area of use

- » Cutting table with water tanks for cutting and plasma cutting processes



### Ideal for

All mechanical and thermal separation and cutting processes

... and many more

### Special design

- » Special enamel

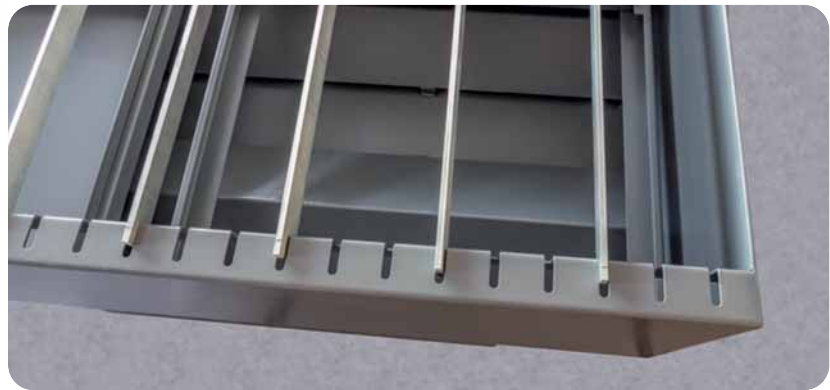

Flat iron support and water trays

**ESTA**PLUS

### Special features

- » Water tanks as material and spark pre-separators
- » Multiple deflection of the airflow to reduce the risk of flying sparks
- » Flat iron support and water trays easy to remove
- » Inspection opening for cleaning the inner housing

### Benefits for you

- » Extraction directly at the workplace
- » Compact solution
- » Protection against harmful particles and smoke that occur during thermal separation
- » Easy disposal of coarse dirt and sludge slag via the water troughs

Data depending on model version

### Technical data

Plasma-cutting table		
Work surface (L/D)	mm	1,100 × 1,100
Working height min./max.	mm	880 / 950
Connection diameter	mm	200
Dimensions (L/W/H)	mm	1,104 × 1,100 × 900
Weight	kg	135
Allowed loading weight of consolidated cargo	kg	200

**Order No. 30013805**

For Easy and High Volume Extraction of Dust and Fumes

RG-100 – RG-800

RG with  
extraction arm

RG mobile



### Application Range

- » Automotive Repair Shops
- » Chemical Industry
- » Construction Industry
- » Flocking Industry
- » Janitorial Cleaning Services
- » Joinery and Carpentry Shops
- » Machine Building Industry
- » Natural and Man Made
- » Paper Industry
- » Printing Industry
- » Stone Processing (Stone Masons)
- » Textile Industry
- » Transportation Businesses
- » Warehouses
- » Work Shops of Skilled Trades

Dust Extractors

High Vacuum  
Extraction Units

Welding Fume  
Filters

Oil Mist  
Separators

Carbon Filters/  
Air Purifier

Downdraft  
Tables

**Extraction Fans**

Extraction Arms

Filter Towers

Central Extraction  
Systems

Pipe Systems

About us

Interesting  
Information

# Extraction Fans

## Introduction and Product Overview

### Introduction

The extractor fans in the **RG series** comprise medium pressure fans that are designed for a range of air extraction and circulation uses.

### Product overview

ESTA extractor fans **RG-100 to RG-800**, with their radial design, take care of airflow and negative pressure in the medium pressure range. They extract smoke-laden air from the extraction point via a suction line to a filter unit, which then separates the particles. Alternatively, the filtering process can be bypassed so that the air is released into the open.

**RG extraction fans with extraction arm** are an effective, economical means of extraction. A fan helps the extraction arm capture the dust or smoke and guide it unfiltered to the desired location (usually outdoors). The idea is to transport the exhaust air to another location inside or outside the building.



The **RG extraction unit with ball joint extraction arm** has a fastening console for wall or ceiling installation. The extraction arm has an oval hood and is two to three metres long.

**RG mobile extraction units** offer a simple, effective, economical solution for dust extraction at changing workstations. The devices are available in three performance levels with filter bag or cartridge filter for recirculation mode.

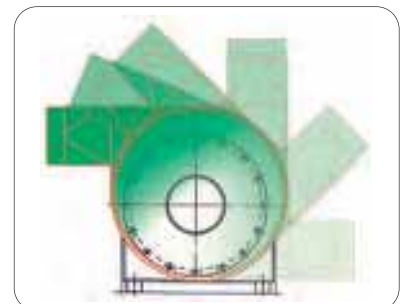

The exhaust outlet of the extracting fans can be adjusted to the desired position (up to and including model RG 300)

## Extraction Fans

### RG-100 to RG-800



Extraction fan RG-300



Extraction fan RG-400

#### Application Range

- » Extraction of individual and multiple workstations in industrial and skilled trade applications
- » In combination with filter units
- » For the extraction mode without filtration
- » For connection to extraction hoods

#### Special features

- » AC current for RG-100 and RG-200
- » Stainless steel (V2A) for the food industry
- » Motor mounted on the left hand side
- » Adjustable exhaust air outlet
- » Explosion proof



#### Ideal for

- Dusts
- Gases
- Odors
- Fumes
- ... and many more



RG-300 in separate room

#### Technical Data

RG		100	200	300
Max. volume flow	m <sup>3</sup> /h	1.000	2.000	3.000
Intake/outlet diameter	mm	100	150	180
Max. negative pressure	Pa	1.400	1.600	2.300
Mains voltage	V	400	400	400
Nominal power	kW	0.55	1.1	2.2
Dimensions (L/W/H)	mm	535×450×480	595×520×555	640×535×610
Sound pressure level	dB(A)	80	82	84
<b>Order Number</b>		<b>01.011</b>	<b>01.021</b>	<b>01.031</b>

#### Technical Data

RG		400	500	600	700	800
Max. volume flow	m <sup>3</sup> /h	3.200	4.000	5.500	7.000	8.000
Intake/outlet diameter	mm	250/315	250/315	315/355	315/400	355/400
Max. negative pressure	Pa	3.150	3.400	3.500	3.400	3.950
Mains voltage	V	400	400	400	400	400
Nominal power	kW	3.0	4.0	5.5	5.5	7.5
Dimensions RG (L/W/H)	mm	711 × 700 × 1.012	711 × 700 × 1.012	737 × 700 × 1.062	762 × 700 × 1.062	820 × 1.000 × 1.198
Sound pressure level	dB(A)	84	84	84	83	84
<b>Order Number</b>		<b>01.441</b>	<b>01.451</b>	<b>01.461</b>	<b>01.471</b>	<b>01.481</b>

#### Your Benefits

- » High performance
- » Heavy duty construction
- » Low operating costs
- » Wide range of applications
- » Small space requirement due to compact design

For other sizes/performance ratings please inquire with us. All equipment will be supplied without motor protection switch.

# Extraction Fans

Extraction Unit

## RG with Extraction Arm



Extraction unit RG-300/extraction arms

### Application Range

- » Extraction of individual and multiple workstations in industrial and skilled trade applications
- » Direct extraction of smoke, gases and fumes
- » Extracting air without filtration



### Ideal for

- Welding fume
- Soldering fume
- Dusts
- Vapors
- ... and many more



Extraction unit RG-200 with 3.0m extraction arm

**ESTAPLUS**

### Special Feature

- » AC current for RG-100 and RG-200 (optional special order models)

### Your Benefits

- » Complete solution made up of an RG extraction fan and extraction arm
- » Source capture with high extraction performance
- » Simple and efficient
- » Different blower sizes
- » Small space requirement due to compact design

### Technical Data

Extraction unit (RG with extraction arm)		RG-100	RG-200	RG-300
Max. volume flow	m <sup>3</sup> /h	1.000	2.000	3.000
Intake opening	mm	100	150	180
Max. negative pressure	Pa	1.400	1.600	2.300
Mains voltage	V	400	400	400
Nominal power	kW	0.55	1.1	2.2
Dimensions RG (L/W/H)	mm	400 × 550 × 500	490 × 600 × 550	540 × 630 × 600
Sound pressure level	dB(A)	80	82	84
Order Number				
with extraction arm, 2,0 m		<b>01.111</b>	<b>01.123</b>	–
with extraction arm, 3,0 m		–	<b>01.121</b>	<b>01.131</b>
with extraction arm, 4,0 m		–	<b>01.122</b>	–



## Extraction Unit

### RG with Ball-Joint Extraction Arm



Extraction unit RG-200/ball joint extraction arm

#### Application Range

- » Extraction of individual and multiple workstations in industrial and skilled trade applications
- » Direct extraction of smoke, gases and fumes with ball-joint extraction arm
- » Extracting air without filtration



#### Ideal for

- Welding fume
- Fumes
- Odorants
- ... and many more



RG-200 with ball joint extraction arm

**ESTA PLUS**

#### Special Features

- » AC current for RG-100 and RG-200 (optional special order models)
- » The installation bracket for ceiling mounting or wall mounting will be included in the scope of supply

#### Your Benefits

- » Complete solution made up of an RG extraction fan and ball-joint extraction arm
- » Source capture with high extraction performance
- » Small space requirement due to compact design
- » Easy handling

#### Technical Data

Extraction unit (RG with extraction arm)	RG-200	
Max. volume flow	m <sup>3</sup> /h	2.000
Intake opening	mm	150
Max. negative pressure	Pa	1.600
Mains voltage	V	230/400
Nominal power	kW	1.1
Dimensions RG (L/W/H)	mm	400 × 600 × 550
Sound pressure level	dB(A)	82

#### Order Number

with extraction arm, 3,0 m	<b>01.121D</b>
with extraction arm, 4,0 m	<b>01.122D</b>

# Extraction Fans

## Mobile Extraction Unit

### *RG with Dust Filter Bag*



Mobile extraction unit RG-300 with dust filter bag

#### Application Range

- » Mobile filter system for dust
- » Connection to processing machines
- » Extraction of individual and multiple workstations in industrial and skilled trade applications



#### Ideal for

Plastic dust

Metal dust

... and many more

#### Special features

- » AC current for RG-100 and RG-200
- » Wall-mount bracket



Wall-mount bracket with cyclone

**ESTA**PLUS

#### Special Feature

- » Available with dust filter bag or long life cartridge

#### Your Benefits

- » Simple and effective filter system
- » Mobile device for flexible use
- » Universal and versatile use

#### Technical Data

Extraction unit, mobile		RG-100	RG-200	RG-300
Max. volume flow	m <sup>3</sup> /h	1.000	2.000	3.000
Intake opening	mm	100	150	180
Max. negative pressure	Pa	1.400	1.600	2.300
Mains voltage	V	400	400	400
Nominal power	kW	0.55	1.1	2.2
Dimensions (L/W/H)	mm	400 × 550 × 500	490 × 600 × 550	540 × 630 × 600
Sound pressure level	dB(A)	80	82	84
<b>Order Number</b>				
with filter bag		<b>04.011</b>	<b>04.021</b>	<b>04.031</b>
with cartridge filter		<b>04.111</b>	<b>04.121</b>	<b>04.131</b>
<b>Wall mount bracket</b>				
with filter bag		<b>08.011</b>	<b>08.021</b>	<b>08.031</b>
with cartridge filter		<b>08.111</b>	<b>08.121</b>	<b>08.131</b>

All extraction units are supplied with an extraction hose of 3.0 m length

Effective and Targeted Source Capture of Dust and Fumes

With flanged hood

With efficiency hood

With square hood

Ball-joint extraction arms

Laboratory extraction arm



## Application Range

- » Automotive Repair Shops
- » Chemical Industry
- » Construction Industry
- » Flocking Industry
- » Joinery and Carpentry Shops
- » Janitorial Cleaning Services
- » Machine Building Industry
- » Metal Industry
- » Natural and Man Made
- » Paper Industry
- » Plastic Industry
- » Printing Industry
- » Stone Processing (Stone Masons)
- » Textile Industry
- » Transportation Businesses
- » Warehouses
- » Work Shops of Skilled Trades

## Test Certification:



# Extraction Arms

## Introduction and Product Overview



### Introduction

ESTA extraction arms are the best solution for the precise, flexible capturing of dusts, vapor and fumes. The ESTA extraction arm's hood can easily be moved to any extraction point and held there reliably. This ensures that your extraction device's suction performance is directed to the exact place where it is needed. Because even the most powerful extraction system is useless if the dust-laden air does not get to the device.

This makes ESTA extraction arms ideal wherever manual work is done or where machines without pipe connections are used. The extraction arm and extraction system must be matched for air performance. For this purpose, ESTA offers a broad selection of extraction arms of various diameters and lengths.

Their great flexibility, easy handling and exterior support structure frame offer the best possible efficiency. Furthermore, premium workmanship gives ESTA extraction arms a long service life.

A wide range of suitable extraction hoods and ATEX versions or high-alloy designs are also available.



## Extraction Arms *Flanged Hood*



Extraction arm with flanged hood

### Application Range

- » Extraction of individual and multiple workstations in industrial and skilled trade applications
- » For connection to extraction unit or pipework



### Ideal for

- Fumes
- Vapors
- Dusts
- Shavings
- ... and many more

### Mounting Possibilities

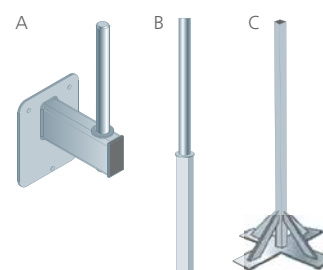

- A Wall-mount console (standard model)
- B Standpipe (for positioning in a suitable holding device at a machine or at the extraction equipment)
- C Floor standpipe, height: 1.000 mm, for extraction arm with standpipe



Extraction arm at a welding station

### Special Features

- » External beam construction
- » Unobstructed air flow inside the extraction arm
- » Gas springs for easy adjustment
- » Optional: reducer and gate valves available for regulating the airflow
- » Optional: installation of lighting
- » Optional: ATEX version

### Your Benefits

- » Large selection of diameters and sizes
- » High flexibility
- » Easy handling
- » Targeted extraction

### Technical Data

Extraction arms with flanged hood										
	Ø 50	Ø 70	Ø 80	Ø 100	Ø 125	Ø 140	Ø 150	Ø 160	Ø 180	Ø 200
<b>Length / Order Number</b>										
1.500 mm	50.152	70.152	80.152	10.152	12.152	14.152	15.152	16.152	18.152	–
2.000 mm	50.202	70.202	80.202	10.202	12.202	14.202	15.202	16.202	18.202	20.202
3.000 mm	50.302	70.302	80.302	10.302	12.302	14.302	15.302	16.302	18.302	20.302
4.000 mm	–	–	–	10.4024	12.4024	14.4024	15.4024	16.4024	–	–
4.000 mm <sup>1)</sup>	–	–	–	10.402	12.402	14.402	15.402	16.402	18.402	20.402
5.000 mm <sup>1)</sup>	–	–	–	10.502	12.502	14.502	15.502	16.502	18.502	20.502
6.000 mm <sup>2)</sup>	–	–	–	10.602	12.602	14.602	15.602	16.602	18.602	20.602
8.000 mm <sup>3)</sup>	–	–	–	10.8024	12.8024	14.8024	15.8024	16.8024	–	–

<sup>1)</sup>inkl. 2.0m extension boom / <sup>2)</sup>inkl. 3.0m extension boom / <sup>3)</sup>inkl. 4.0m extension boom

# Extraction Arms

Suction arms

## Efficiency hood



Suction arm with efficiency hood

### Areas of application

- » For precise detection of smoke and dust
- » Single and multiple extraction points in industry and crafts
- » For connection to suction unit or pipeline



### Ideal for

- Fumes
- Vapors
- Dusts
- Shavings
- ... and many more

Enlargement of the detection area  
**up to 30%**

### Mounting Possibilities

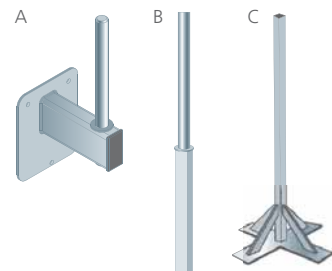

A Wall-mount console (standard model)

B Standpipe (for positioning in a suitable holding device at a machine or at the extraction equipment)

C Floor standpipe, height: 1.000 mm, for extraction arm with standpipe

**ESTAPLUS**

### Special features

- » External carrierconstruction
- » Air flow inside is not hindered
- » Gas springs for easy mobility
- » Optional: throttle and shut-off valvesfor control of suction air available
- » Optional: installation of lighting possible

### Benefits for you

- » High flexibility
- » Easy handling
- » Exact detection

Data depending on model version

### Technical Data

#### Extraction arms with efficiency hood

Ø 140

#### Length / Order Number

1.500 mm	<b>14.154</b>
2.000 mm	<b>14.204</b>
3.000 mm	<b>14.304</b>
4.000 mm <sup>1)</sup>	<b>14.404</b>
5.000 mm <sup>1)</sup>	<b>14.504</b>
6.000 mm <sup>2)</sup>	<b>14.604</b>

<sup>1)</sup>incl. 2,0m extension boom / <sup>2)</sup>incl. 3,0m extension boom

## Extraction Arms *Square Hood*



Extraction arm with square hood

### Application Range

- » For large-area sensing of dust and fume
- » Extraction of individual and multiple workstations in industrial and skilled trade applications
- » Connection to extraction unit or pipework



### Ideal for

- Fumes
- Vapors
- Dusts
- ... and many more



Square hood with baffle plate at a weighing station

**ESTA PLUS**

### Special Features

- » External beam construction
- » Unobstructed air flow inside the extraction arm
- » Gas springs for easy adjustment
- » Optional: reducer and gate valves available for regulating the airflow
- » Optional: ATEX version

### Your Benefits

- » Large capturing area
- » Easy handling
- » High Flexibility

### Technical Data

Extraction arms with square hood						
	Ø 100	Ø 125	Ø 140	Ø 150	Ø 160	Ø 180
Hood: 500 x 500 mm	✓	✓	-	-	-	-
Hood: 600 x 600 mm	-	-	✓	✓	✓	✓
Length / Order Number						
1.500 mm	10.153	12.153	14.153	15.153	16.153	18.153
2.000 mm	10.203	12.203	14.203	15.203	16.203	18.203
3.000 mm	10.303	12.303	14.303	15.303	16.303	18.303
4.000 mm	10.4034	12.4034	14.4034	15.4034	16.4034	-
4.000 mm <sup>1)</sup>	10.403	12.403	14.403	15.403	16.403	18.403
5.000 mm <sup>1)</sup>	10.503	12.503	14.503	15.503	16.503	18.503
6.000 mm <sup>2)</sup>	10.603	12.603	14.603	15.603	16.603	18.603
8.000 mm <sup>3)</sup>	10.8034	12.8034	14.8034	15.8034	16.8034	-

<sup>1)</sup> incl. 2.0m extension boom / <sup>2)</sup> incl. 3.0m extension boom / <sup>3)</sup> incl. 4.0m extension boom

- Dust Extractors
- High Vacuum Extraction Units
- Welding Fume Filters
- Oil Mist Separators
- Carbon Filters / Air Purifier
- Downdraft Tables
- Extraction Fans
- Extraction Arms**
- Filter Towers
- Central Extraction Systems
- Pipe Systems
- About us
- Interesting Information

## Ball-Joint Extraction Arms



Ball-joint-extraction arm

### Application Range

- » For flexible sensing of fume
- » Extraction of individual and multiple workstations in industrial and skilled trade applications
- » Connection to blower or extraction unit pipework



### Ideal for

Welding fume

Vapors

... and many more



Ball-joint-extraction arm in use

**ESTA**PLUS

### Special Features

- » Swivel range:
  - ceiling mounted unit 360°
  - wall mounted unit 180°
- » External beam construction
- » Unobstructed air flow inside the extraction arm
- » Gas springs for easy adjustment
- » Optional reducer and gate valves available for regulating the airflow
- » Optional installation of lighting
- » Optional ATEX version

### Your Benefits

- » Low maintenance
- » For ceiling and wall mounting
- » Easy handling
- » Can accommodate large work areas

### Technical Data

#### Ball-joint extraction arm with oval hood

	Ø 80	Ø 100	Ø 125	Ø 140	Ø 150	Ø 160	Ø 180
<b>Length / Order Number</b>							
2.000 mm	80.202D	10.202D	12.202D	14.202D	15.202D	16.202D	18.202D
3.000 mm	80.302D	10.302D	12.302D	14.302D	15.302D	16.302D	18.302D
4.000 mm	-	10.402D	12.402D	14.402D	15.402D	16.402D	18.402D

#### Ball-joint extraction arm with square hood

<b>Length / Order Number</b>							
2.000 mm	-	10.203D	12.203D	14.203D	15.203D	16.203D	18.203D
3.000 mm	-	10.303D	12.303D	14.303D	15.303D	16.303D	18.303D
4.000 mm	-	10.403D	12.403D	14.403D	15.403D	16.403D	18.403D



## Laboratory Extraction Arm 50 D



Laboratory extraction arm 50 D

### Application Range

- » Extraction of individual and multiple workstations in laboratories, industrial and skilled trade applications
- » For the precise sensing of fine dusts and fumes
- » Dental laboratories

### Ideal for

- Soldering fumes
- Dusts
- Odorants
- Vapors
- ... and many more



Multiple extraction units for the extraction of solder fumes

**ESTA PLUS**

### Special Features

- » Airflow control valve
- » Wall mounting, table mounting or clamping fixture
- » Ceiling mounting is possible with a special bracket
- » Choice of six different types of extraction hoods
- » Optional integrated lighting
- » Optional ATEX version

### Your Benefits

- » Precise sensing
- » Space saving
- » Extraction hood for any application
- » Easy handling



Extraction hood with round orifice and integrated lighting



Airflow valve to regulate the extraction volume

### Technical Data

<b>Laboratory extraction arm incl. table mounting device</b>	<b>50 D</b>
Total extension	mm <b>900</b>
<b>Order Number</b>	<b>50.080</b>

Dust Extractors

High Vacuum Extraction Units

Welding Fume Filters

Oil Mist Separators

Carbon Filters/ Air Purifier

Downdraft Tables

Extraction Fans

**Extraction Arms**

Filter Towers

Central Extraction Systems

Pipe Systems

About us

Interesting Information

## FILTOWER



### ***Application Range***

- » Aircraft construction
- » Automobile industry
- » Chemical industry
- » Food industry
- » Machine building industry
- » Metal industry
- » Plastics industry
- » Shipbuilding industry
- » Stone Industry
- » Vehicle construction

## FILTOWER-F



### Applications

- » Supplemental solution for compliance with dust limits where local capture is not alone sufficient
- » To provide support for direct extraction
- » For improving room air quality
- » For welding processes for which local capture is not practical



### Ideal for

- Welding and soldering fumes
- Fine dusts
- Plastic dusts
- Chemical dusts
- Bulk material applications
- Aerosols
- Oil and emulsion mist
- Vapours
- ... and many more

**ESTAPLUS**

### Special Features

- » Up to 70% savings on heating costs through recirculation mode
- » Simple and intuitive system operation via generous display
- » ESTA Quick-Change filter replacement system – quick & dust-free
- » Continuous filter cartridges with nanofibres (separation performance 99.9%)
- » Innovative pre-separator system

### Your Benefits

- » Improving air quality for all employees in production halls
- » Support with compliance with legally-required dust limits
- » Plug & Play filter tower: Install, connect to mains, compressed air supply – you are done
- » Frequency converters ensure controllable & energy-saving plant operation
- » Powerful, low-noise extraction
- » No pipeline installations needed
- » Flexible uses, easy to move with forklift or crane
- » Low operating costs

Data dependent on equipment type



Intuitive device control



Movable dust collection drawer

Dust Extractors

High Vacuum Extraction Units

Welding Fume Filters

Oil Mist Separators

Carbon Filters/ Air Purifier

Downdraft Tables

Extraction Fans

Extraction Arms

Filter Towers

Central Extraction Systems

Pipe Systems

About us

Interesting Information

## FILTOWER

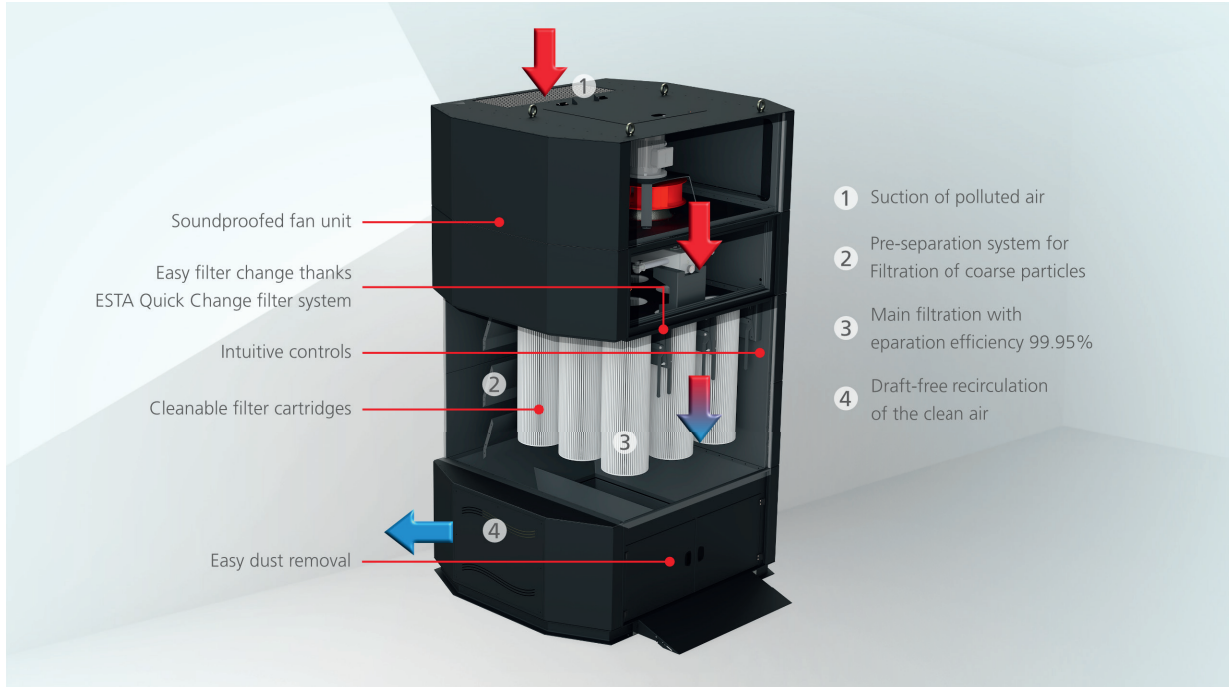

### Technical Data

FILTOWER		160	200
Max. volume flow	m <sup>3</sup> /h	12,000	18,000
Mains voltage	V	400	400
Nominal power	kW	7,5	2 × 7,5
Main filter surface	m <sup>2</sup>	157,5	225
Main filter quantity	Stück	9	9
Collection volume	l	300	300
Dimensions (L/W/H)	mm	1,800 × 2,250 × 3,500	1,800 × 2,250 × 3,950
Weight	kg	1,320	1,800
Sound pressure level	dB(A)	72	72
<b>Order Number</b>			
Standard		<b>899160</b>	<b>899200</b>

## Central Extraction Systems Tailored to Your Application

Side Channel  
Blowers

High and Medium  
Pressure Fans

Rotary Piston  
Blowers

Filter Cyclones

Modular  
Filter Systems

Ventilation of  
Production Facilities

Extraction Hoods

Soundproofed Cabins



### Application Range

- » Aerospace Engineering
- » Agricultural Processing
- » Aircraft Industry
- » Automotive Repair Shops
- » Automotive Supplier Industry
- » Construction Industry
- » Electronics Industry
- » Engine Manufacturing Plants
- » File Shredding
- » Food Processing Industry
- » Machine Building Industry
- » Metalworking Industry
- » Mills
- » Paper Industry
- » Pharmaceutical Industry
- » Plastics Processing Plants
- » Precision Mechanical Industry
- » Printing Industry
- » Processing Facilities
- » Recycling and Waste
- » Research and Development
- » Ship Building Industry
- » Shoe Manufacturing Plants
- » Tobacco Companies
- » Vacuum Systems
- » Vehicle and Auto Body Plants
- » Welding Facilities

# Central Extraction Systems

## Introduction and Product Overview



### Introduction

Central extraction systems can extract dust simultaneously from multiple nozzles or machines through a suitable pipe system. Whether you need to extract coarse or fine dust, wet or dry, vapours or smoke - ESTA extraction systems can be adapted to the requirements of each specific application. The modular design of ESTA central dust extraction systems makes it possible to offer systems that are customized to your specific application. Our sales engineers will configure the optimal system including a suitable pipe system, filtration unit and a central vacuum generator.

### ESTA central extraction systems offer many advantages:

- Very high efficiency of the vacuum generator
- Quiet operation through sound insulation and if necessary special sound dampening enclosures
- Wear resistant and maintenance free design
- Low operating costs through cleanable long life filters and high energy efficiency of the systems
- Modern control cabinets in all variants
- Complete service – from design through installation to start-up operation and maintenance



### Benefit from our over 50 years of experience with extraction technology.

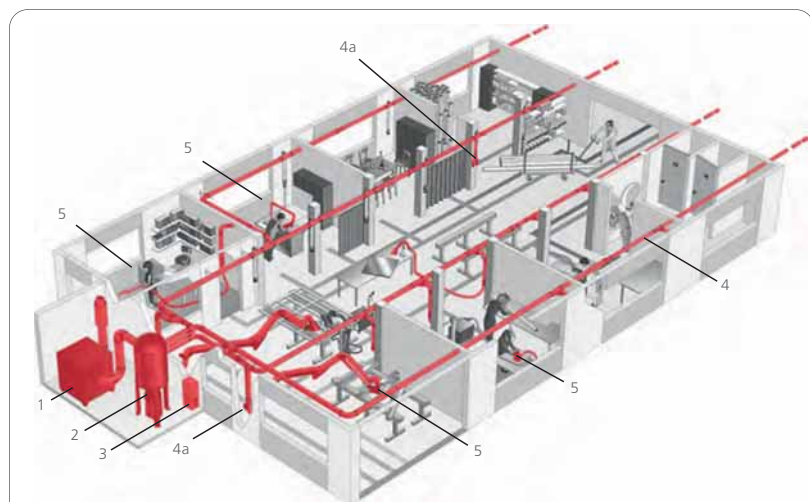

- |  |  |
|--|--|
| <p><b>1 Central Vacuum Producer</b><br/>Side channel blowers, fans, rotary piston blowers, high and medium pressure fans</p> | <p><b>3 Electric Control Unit</b></p>  |
| <p><b>2 Filtration Unit</b><br/>Cyclone, Modular filtration units</p>  | <p><b>4 Pipe System</b><br/>Flapper valves (4a)</p>                                  |
|  | <p><b>5 Extraction Devices</b><br/>Extraction hoods, extraction arms and nozzles</p> |

## Switch cabinets for every requirement

The complete switch cabinet construction is part of our core disciplines along the valuecreation chain. The construction of the emergency circuit diagrams are created with EPlan.

We manufacture exclusively in our factory in Germany. We attach the utmost importance to excellent quality, national, international and customer-specific standards.



### Variations

Control cabinet BASIC up to 22 kW

- Central control of the plant
- Optical indication of the operating status
- Separate optical display in the event of a fault at the cleaning control
- Optical indication of malfunctions

Control cabinet KOMFORT up to 22 kW

- Central control of the plant
- Optical display Operation ON
- Information output and operation via panel
- Maintenance indicator
- Faults and warnings with text
- Operating hours display
- Free floating contact for Start/Stop
- Free floating contact signal for operation/fault

### Operating panels

In addition to the classic, mechanical operating elements, we install also components such as touch panels. This ensures maximum user-friendliness and visualisation of the necessary operating data.



### Further features

- Supply voltage 324 - 572 V AC
- No N conductor necessary
- Cable entry system
- Integrated system protection



### Individual production

Many of our customers require special solutions in unique designs. Thanks to our experience, we are able to manufacture control cabinets individually and efficiently from a single piece. Whether individual lacquering, production of customer-specific housings or design and large-area attachment of labelling foils, we tailor all elements exactly to your requirements.

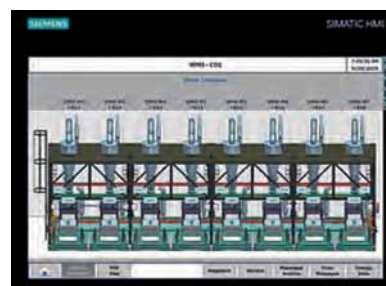

- Dust Extractors
- High Vacuum Extraction Units
- Welding Fume Filters
- Oil Mist Separators
- Carbon Filters/ Air Purifier
- Downdraft Tables
- Extraction Fans
- Extraction Arms
- Filter Towers
- Central Extraction Systems**
- Pipe Systems
- About us
- Interesting Information

## Side Channel Blowers



Schematic illustration of a side channel blower with direct drive



ESTA side channel blowers are assemblies used when strong suction power is needed. This includes central dust extraction systems in production areas, power plants, trash incinerators, manufacturing areas, etc.

The compressors are also available in an ATEX-compliant design.



Central vacuum unit equipped with two side channel blowers

**ESTA PLUS**

### Application Range

- » Extraction from multiple workstations in industrial manufacturing and processing
- » Multi-shift operation possible
- » Optional: ATEX version

### Your Benefits

- » High negative pressure
- » Quiet operation through sound insulation and suitable positioning
- » Wear and maintenance free design
- » Low operating costs through high energy efficiency

### Technical Data

Side Channel Blowers		TDS-13	TDS-18.5	TDS-22	TDP-11	TDP-18.5	TDP-22	TDP-26
Max. volume flow	m <sup>3</sup> /h	1.140	1.140	1.140	790	2.100	2.100	2.100
Intake opening	mm	140	140	140	100	180	180	180
Max. negative pressure	Pa	23.500	38.000	40.500	30.000	23.500	27.000	31.500
Mains voltage	V	400	400	400	400	400	400	400
Nominal power	kW	13.0	18.5	22.0	11.0	18.5	22.0	26.0
Motor speed	1/min	3.000	3.000	3.000	3.000	3.000	3.000	3.000
Dimensions (W×H×D)	mm	990 × 1.730 × 1.200						
Sound pressure level	dB(A)	78	96	90	85	93	88	93

**Order Number**                      **301.101 301.103 301.105 301.100 301.102 301.104 301.106**

Please inquire with us about additional units





## Rotary Piston Blowers



Rotary piston blower



ESTA rotary blowers are intended for use where there is high negative pressure while air flow remains constant.

Their combination with the ESTA FZ cyclone filter is the core of a reliable high-vacuum extraction system.

Especially for process extraction systems, or for long, wide-branching pipeline systems, rotary blowers are the right choice.



Rotary piston blower application photo

### Application Range

- » Extraction from multiple workstations in industrial manufacturing and processing
- » Applications where constant negative pressure is required

### Your Benefits

- » Extremely constant negative pressure
- » Quiet operation through sound insulation and remote positioning
- » Industrial strength and maintenance free design
- » Low operating costs through high energy efficiency

### Technical Data

Rotary piston blowers		DKG-11	DKG-15	DKG-37	DKG-75
Max. volume flow	m <sup>3</sup> /h	510	840	1.860	3.720
Intake opening	mm	80	100	150	200
Max. negative pressure	Pa	40.000	40.000	40.000	40.000
Mains voltage	V	400	400	400	400
Nominal power	kW	11.0	15.0	37.0	75.0
Motor speed	1/min	2.915	2.925	2.945	2.970
Dimensions (W×H×D)	mm	1.230 × 1.306 × 1.200	1.230 × 1.306 × 1.200	1.655 × 1.820 × 1.600	2.110 × 2.330 × 1.750
Weight	kg	550	600	1.180	2.500
Sound pressure level	dB(A)	71	72	78	85
<b>Order Number</b>		<b>302.101</b>	<b>302.102</b>	<b>302.103</b>	<b>302.104</b>

Please inquire with us about additional units

## Cyclonic Filtration Units



Cyclonic filtration unit

### Application Range

- » Extraction from multiple workstations in industrial manufacturing and processing
- » As a filter for high-vacuum extraction
- » For the deposition of dust, shavings and fumes



### Ideal for

- Metal dust
- Plastic dust
- Shavings of all kinds
- CRP-/GRP-dusts
- CRP-/GRP-shavings
- ... and much more

### Special Version

- » ATEX version



Two cyclonic filters as part of an extraction system

**ESTAPLUS**

### Special Features

- » Compact design
- » Suitable for continuous operation

### Your Benefits

- » The dual filter system is suitable for coarse and fine dust
- » Quiet operation through sound insulation and remote positioning
- » Industrial duty and maintenance free design
- » Low operating costs through cleanable filters and high energy efficiency
- » Suitable for applications requiring high negative pressure

### Technical Data

Cyclonic filtration unit	FZ-1003	FZ-1503	FZ-3003	FZ-5003	FZ-7003	FZ-11003
Cartridge filter (dia./L)	150/660	150/1.000	325/600	325/1.000	325/600	325/1.000
Intake opening* mm	159	159	355	355	400	400
Main filter quantity Pieces	4	4	3	3	7	7
Main filter surface per cartridge m <sup>2</sup>	2.5	3.6	10	16.7	10	16.7
Main filter surface m <sup>2</sup>	10	14.4	30	50	70	117
Collection volume l	100	100	100	100	200	200
Dimensions (dia./H) mm	674 / 2.280	674 / 2.580	1.335 / 3.120	1.335 / 3.450	1.915 / 3.866	1.915 / 4.270
Diameter mm	600	600	1.259	1.259	1.800	1.800
<b>Order Number</b>	<b>300.027</b>	<b>300.031</b>	<b>300.032</b>	<b>300.033</b>	<b>300.034</b>	<b>300.035</b>

Please inquire with us about additional units

\* Depending on the type of application

## Modular Extractors DUSTMAC



Filter unit DUSTMAC P

### Application Range

- » Extraction from multiple workstations in industrial manufacturing and processing
- » As a filter unit for medium pressure systems up to 15,000 Pascal

### Ideal for

- Metal dust
- Welding fume
- Concrete dust
- Plastic dust
- Fibrous materials
- ... and many more



DUSTMAC F-144 in the metalworking industry

**ESTA PLUS**

### Special Features

- » Highly efficient filter cleaning process during operation of the system
- » The modular design makes it possible to adapt the system to each specific application
- » Special design features make use of pre-separation principles
- » Supplied with cartridge or tubular bag filter

### Your Benefits

- » Modular design (expandable as your production expands)
- » Adaptable to "Your" particular type of dust
- » Customer specific system configuration
- » Low operating costs due to cleanable filter media
- » Small space requirement due to compact design

Data dependent on equipment type



DUSTMAC P (with cartridge filters)



DUSTMAC S (with tubular bag filters)

### Technical Data

	Page
<b>DUSTMAC P</b> with cartridge filters – Complete system	23
<b>DUSTMAC S</b> with tubular bag filters – Complete system	24
<b>DUSTMAC F</b> for welding fume – Complete system	46
<b>DUSTMAC</b> for custom configurations	83

## Custom Configurations DUSTMAC

With DUSTMAC-series modular filter units, individual system designs can be created for central multi-user extraction – for nearly any type of dust and almost any industry.

Based on the type, volume and amount of dust, an appropriate filter is used in the system housing. Even a suitable fan (such as MDV or RG) can be integrated into the system design based on specific requirements. Then a pipe system can connect the system to any number of extraction points.



Individual plant concept with DUSTMAC filter units in the shoe industry

### Dust Removal

Collection and removal of the extracted dust – with three different methods depending on your application. For additional collection and removal options kindly contact us.



Mobile dust collection container



Removal through rotary valve



Directly into a container

**Other discharge variants on request.**

## Cyclonic Filtration Units

The modular design of the ESTA DUSTMAC model series makes it possible to adapt these central extraction systems to the individual applications and conditions at the customer's production facilities. This guarantees that our customers receive the most suitable extraction system for their particular situation.

Our sales engineers are always available for a personal consultation at your company to determine the best possible configuration of your extraction system.



### Extraction Fans

Generally there are two types of extraction fans – high and medium pressure fans. Medium pressure fans are characterized by high airflow volumes to ensure the most complete extraction of the dust or fumes to be captured.

High pressure fans produce high air velocity to capture dust or fumes at the source. Fans with an output of up to 15 kW are usually mounted on the filtration unit. Larger fans will be positioned as stand alone units next to the filtration units (see Page 78).

### Filtration Unit

The filtration unit(s) is (are) the “heart” of the central extraction system. Depending on the type of dust, quantity of dust and its composition the filtration units will be equipped with different types of filters.

During and after operation the filters will automatically be cleaned with a pulse-jet cleaning system. The geometry of the filter housing is a key factor for a long filter life and for effective filter cleaning. It ensures the ventilation technologically correct airflow conditions inside the filter housing.

### Dust Removal

There are several methods available to collect the material that has been filtered out. In most cases the dust will be collected in a drum that is positioned at the tapered bottom of the filtration units.

For this purpose we have drums of 50, 100 or 200 Litres capacity available. Other methods are rotary valves for continuous removal, high capacity containers, shuttle valves or pinch valves.

## Modular welding smoke filter unit *WELDEX FE*



Central filter unit with extinguishing system in a welding fume extraction system



### Areas of application

- » Spatial ventilation for welding-work, push-pull processes and layer ventilation
- » Welding fume extraction on hoods and extraction arms
- » Cabin extraction
- » Extraction with robotwelding and on automated production lines
- » Extraction on flame, plasma and laser cutting tables

### Special features

- » For welding fume extraction for air volumes up to 150,000 m<sup>3</sup>/h
- » Modular design and expandable
- » Filter materials suitable for the application
- » Pre-separator and extinguishing system to minimise fire risks
- » Can be combined with heat recovery systems

### Benefits for you

- » Compact design
  - » All components are integrated in weatherproof housing
  - » **ESTA Quick-Change filter-changing system** for fast and low dust filter change
  - » Optimum accessibility of all system components
  - » Wide range of control variants including ESTA *eco*<sup>+</sup> control for minimum energy consumption
- Data depending on model version

# Central Extraction Systems

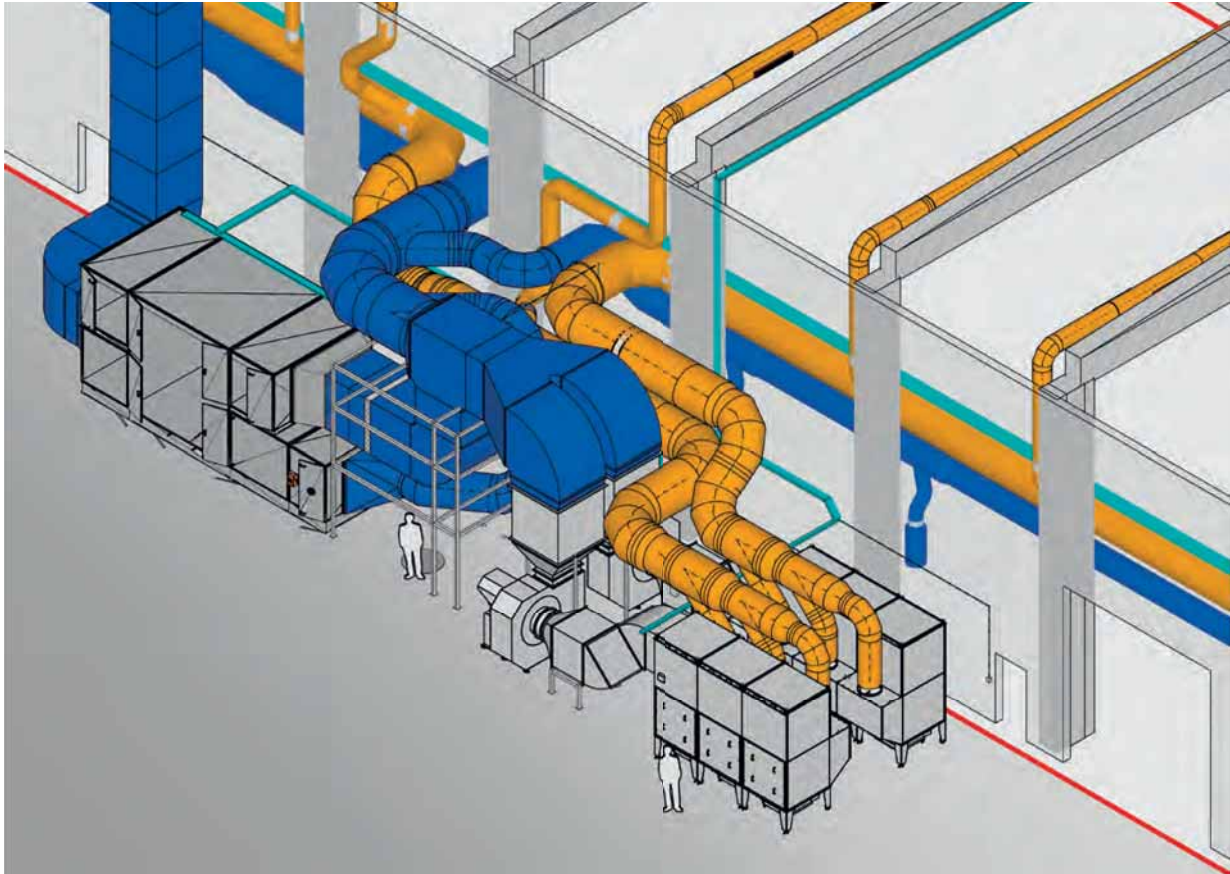

Two extraction systems for welding fumes with one WELDEX F450 filter unit each

## Details

Modular design of WELDEX filter units



WELDEX F225 with one module



WELDEX F450 with two modules

## Technical data

WELDEX filter unit		F225	F450	F675
Main filter surface	m <sup>2</sup>	225	450	675
Main filter quantity	Unit	9	18	27
Dimensions (D/W/H)	approx. mm	2,130 × 1,510 × 2,970	2,130 × 4,150 × 2,970	2,130 × 5,600 × 2,970
Weight	approx. kg	800	1,550	2,300

Technical data per filter unit  
Other model sizes on request!



## Ventilation of Production Facilities

In some production areas or manufacturing processes, particle size or other production conditions make it impossible to extract fumes directly. For this, ESTA offers various concepts for hall ventilation.

Here all the air in these spaces is cleaned of smoke and dust particles to comply with applicable regulations and to create a pleasant environment in the hall.

The core of this concept is the WELDEX series. Its modular design handles any volume of air and allows combination with additional devices, such as heat exchangers,

heating and cooling registers, etc.

The ESTA FILTOWER series filter tower works as a free-standing system to clean the air in the hall without a pipe-line connection.

This allows the system to be moved anywhere within the hall, at any time, and at no cost.

### Ideal for

Cleaning the hall's air of welding fumes, oil mist and airborne dusts through thermal ventilation.



WELDEX FE



FILTOWER Series



ESTA Upstream Stratification Ventilation

ESTAPLUS

### Your Benefits

- » Reduction of the operating costs through energy efficient designs including heat reclamation
- » Flexibility in the work area (no changes in the pipe systems are required in the event of machine layout changes)
- » Constantly optimised fresh air quality
- » Minimal life cycle costs with ESTA filter cleaning service

### ESTA Upstream Stratification Ventilation

- » Building ceiling height > 7,5 m
- » High thermal loads, welding rod consumption > 10 tons per year
- » Fresh air supply vents near the floor to generate a layer of cool air
- » Temperature control in connection with heat recovery possible
- » Low air flow rates sufficient
- » Suitable for cooling

### ESTA Push Pull Mixing Ventilation

- » Building ceiling height < 7,5 m
- » Low thermal loads, welding rod consumption < 10 tons per year
- » Special long-range air jets
- » Temperature control in connection with heat recovery possible
- » Two pipe systems located opposite of each other
- » Suitable for heating and cooling

Dust Extractors

High Vacuum Extraction Units

Welding Fume Filters

Oil Mist Separators

Carbon Filters/ Air Purifier

Downdraft Tables

Extraction Fans

Extraction Arms

Filter Towers

Central Extraction Systems

Pipe Systems

About us

Interesting Information

## Ventilation of Production Facilities

### ESTA Push Pull Mixing Ventilation

#### Operating Principle:

- Fresh air supply and contaminated room air are mixed vigorously
- Temperature and contaminant concentration are equally distributed in the work area
- A stream of air is blown into the room from the wall on one side – horizontally to the room – and then extracted at the wall on the opposite side of the room
- The filtered air can be returned and summer/winter operation is possible through an air handling unit with optional heat reclamation, heating and cooling

Incoming air pipe system with long-range nozzles

Extraction pipe system with intake vents

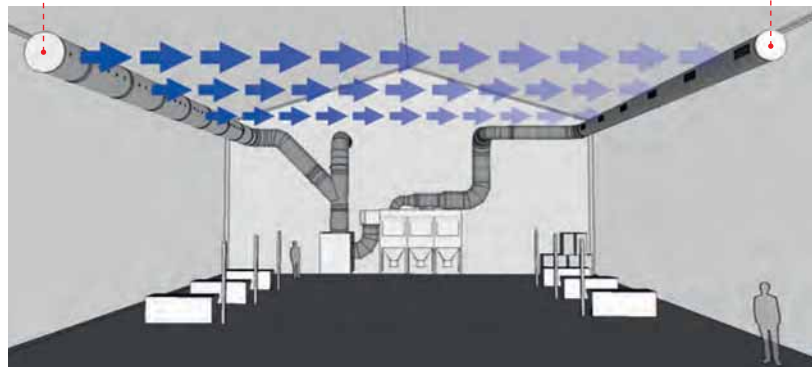

Product-Video

### ESTA Upstream Stratification Ventilation

#### Operating Principle:

- The plume generated at the welding location transports heat and contaminants to the upper area of the manufacturing facility
- At the floor level of the plant the flow volume generated by the updraft is replaced by a cooler low flow air supply

- Consequently two separate layers of air are forming in the production facility – one with fresh air in the work area and one with contaminated air in the upper part of the facility

- Return of filtered air and summer/winter switchover through an air handling unit with optional heat reclamation, heating and cooling
- Fully automated control of the fresh air volume via temperature sensors

Fresh air intake (Optional: Cooling)

Low flow air supply into the plant with room temperature <math>< 4^{\circ}\text{C}</math> at air inleat

Extraction pipe system

Air supply pipe system

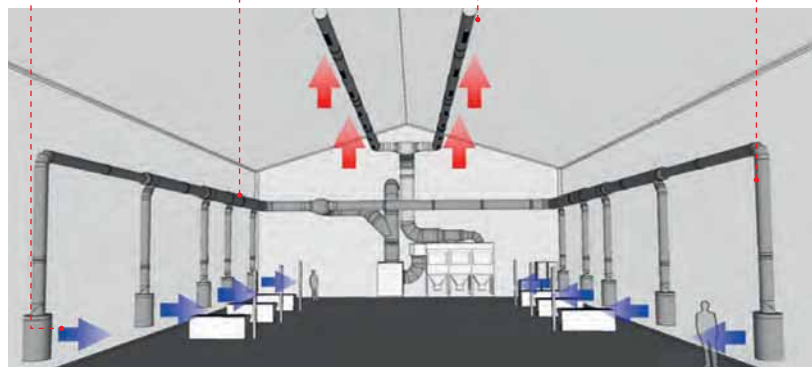

**ESTA** PLUS

#### Your Benefits

- » ESTA layout planning according to VDI/DVS guideline 6005 and TRGS regulation 528/560
- » Software supported customised consulting at the customer's premises
- » Visualisation of the ventilation system prior to the installation

## Extraction Hoods

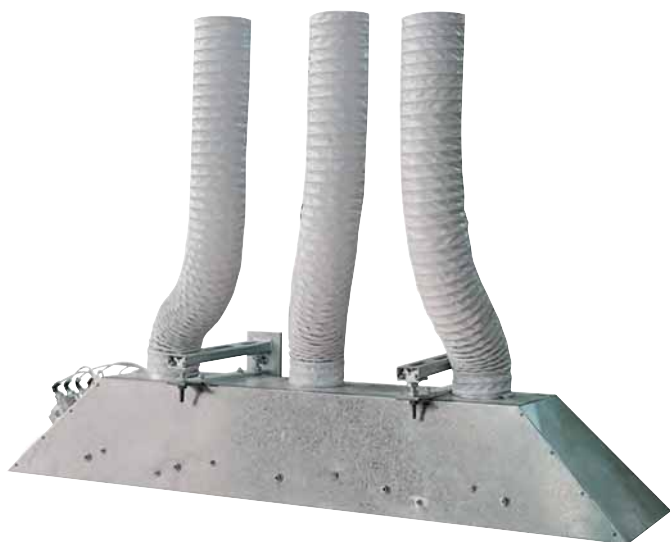

Extraction hood with compressed air injection

### Ideal for

All manufacturing processes in which dust, shavings, fumes and smoke gases to be detected and derived



Extraction at a robotic workstation

### Application Examples



Slotted extraction hoods in the automotive industry



Extraction wall with perforated metal insert



Large surface extraction hood in the concrete industry



Extraction wall on a DUSTOMAT-S



Specialized hood 120 x 30 cm



Extraction of aluminium shavings

ESTA PLUS

#### Special Features

- » Wide range of standard hoods
- » Individual calculation of the extraction hoods according to ventilation technologically optimised principles
- » Pipe pre-separator
- » Recommended for the best possible extraction of dust and fumes-Maßgeschneiderte Haube

#### Your Benefits

- » Tailor-made hoods for almost any application
- » Wear resistant and low maintenance designs

Dust Extractors

High Vacuum Extraction Units

Welding Fume Filters

Oil Mist Separators

Carbon Filters/Air Purifier

Downdraft Tables

Extraction Fans

Extraction Arms

Filter Towers

Central Extraction Systems

Pipe Systems

About us

Interesting Information

## Soundproofed extraction cabins

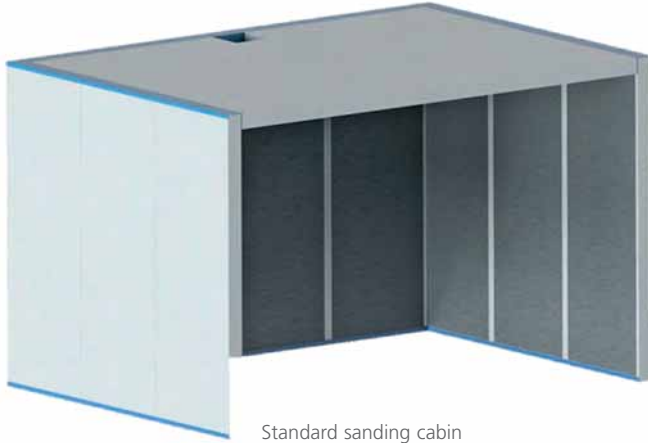

Standard sanding cabin

### Ideal for

Machine or robot housings

Work cabins

Grinding workstations

Welding smoke/dust

... and many more

ESTA extraction cabins offer extraction and sound insulation in one. They enclose dust and smoke generating workplaces or machines and prevent the release of pollutants into adjacent work areas. Furthermore, with the appropriate extraction technology, the exposure of employees to dust or smoke can be reduced and statutory regulations can be complied with.

The cabins are suitable, among other things, for extraction during welding, grinding, cutting, polishing and for almost all materials (metal, stone, plastic, etc.) which produce particles during processing.

### Application

- » Extraction of dust and smoke particles as well as sound-reduction at workplaces or machines

### Special features

- » Modular design
- » Integral construction
- » Flexible setup
- » Optionally with powder-coated exterior in RAL colour
- » Optionally with viewing windows

### Benefit

- » Wide range of applications
- » Noise protection and suction in one
- » No contamination of adjacent areas
- » Easy assembly

Data depending on model version

### Accessories/special equipment

- » Lamella curtain, fixed
- » Lamella curtain, slidable
- » Industrial curtain  
Industrial curtain, DIN 1598 (welder) Sight window made of safety glass
- » LED lighting (IP65, ATEX)



4-fold grinding cabin with rolling doors

## Soundproofed extraction cabins

### Basic cabin body

#### Basic cabin body height 2500 mm – RAL 7035

interior height 2400 mm

Dimensions L x W in metres		Side B (width) Outer dimension					Max. Number of windows side B
		2	3	4	5	6	
Side A (width) Outer dimension	2	AN000135	AN000136	AN000137	AN000138	AN000139	2
	3	AN000140	AN000141	AN000142	AN000143	AN000144	4
	4	AN000145	AN000146	AN000147	AN000148	AN000149	5
	5	AN000150	AN000151	AN000152	AN000153	AN000154	6
	6	AN000155	AN000156	AN000157	AN000158	AN000159	8
Max. Number of windows side A		2	4	5	6	8	

#### Basic cabin body height 3000 mm – RAL 7035

interior height 2900 mm

Dimensions L x W in metres		Side B (width) Outer dimension					Max. Number of windows side B
		2	3	4	5	6	
Side A (width) Outer dimension	2	AN000160	AN000161	AN000162	AN000163	AN000164	2
	3	AN000165	AN000166	AN000167	AN000168	AN000169	4
	4	AN000170	AN000171	AN000172	AN000173	AN000174	5
	5	AN000175	AN000176	AN000177	AN000178	AN000179	6
	6	AN000180	AN000181	AN000182	AN000183	AN000184	8
Max. Number of windows side A		2	4	5	6	8	

### Accessories

#### Lamellae curtain

Clear/transparent, Strip width 300/2

	Art. no.
<b>Lamellae curtain</b> , 2700 mm high, fixed, PVC, per metre	AN000188
<b>Lamellae curtain</b> , 2700 mm high, sliding, PVC, per metre	AN000189
<b>Lamellae curtain</b> , 2200 mm high, fixed, PVC, per metre	AN000190
<b>Lamellae curtain</b> , 2200 mm high, sliding, PVC, per metre	AN000191

#### Safety glass viewing pane

	Art. no.
<b>Viewing pane</b> 600 mm x 800 mm, VSG 8	AN000185
<b>Viewing pane</b> 600 mm x 1000 mm, VSG 8	AN000186
<b>Front pane red</b> , DIN 1598, Protective pane for viewing window, 600 x 800 mm	AN000187

#### Lamellae curtain

Bronze/transparent/Welding place (green or red), Strip width 300/2

	Art. no.
<b>Lamellae curtain</b> , 2700 mm high, fixed, DIN 1598, per metre	AN000192
<b>Lamellae curtain</b> , 2700 mm high, sliding, DIN 1598, per metre	AN000193
<b>Lamellae curtain</b> , 2200 mm high, fixed, DIN 1598, per metre	AN000194
<b>Lamellae curtain</b> , 2200 mm high, sliding, DIN 1598, per metre	AN000195

#### Lighting

	Art. no.
<b>Electrical connection set for lighting</b>	AN000196
<b>LED Damp-proof luminaire IP 65</b>	AN000197
<b>LED Recessed light panel IP 54</b> , approx. 600 x 600 mm	AN000198
<b>LED ATEX Lighting</b>	AN000199

## References

Holz Carwash Systems – Senden, Germany

ESTA Sales and  
Distribution Partner



### Dust extraction system for cleaning car interiors at car washes, filling stations and auto dealers

Central vacuum systems are gaining increasing popularity for commercial use in cleaning the interior of vehicles.

Theoretically an unlimited number of vacuum stations can be set up whereby the vacuum performance remains constant.

Central vacuum systems make much more efficient use of your property (number of possible vehicle vacuum stations) compared to solutions with individual vacuum systems.



Central Car Cleaning System for outdoor installation



Inner workings of the CENTRAL CAR CLEANING SYSTEM



Dust extraction at multiple vacuum locations



With crevice tool for easy cleaning of the interior space



The mobile dust collection container with an inserted plastic bag allows easy, dust-free disposal of extracted dirt



A rigid pipe installation connects the vacuum locations with the cyclonic filter

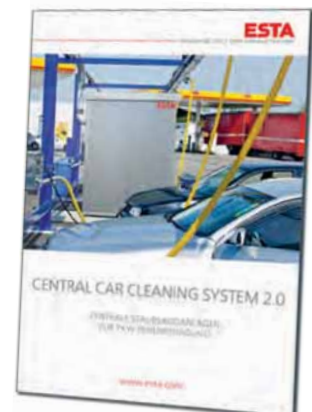

Contact us for a brochure with more detailed information.

## References

### HG-Micro-Instrumente, Wurmlingen

Medical technology

Extraction of the dust produced during slag processing



DUSTOMAT Hydro wet separator in the grinding shop



Grinding the titanium parts

DUSTOMAT HYDRO

Control cabinet convenience

Ducting system for extraction at the four workplaces

### ebm-papst Mulfingen GmbH & Co. KG

Ventilation and drive technology

Extraction of aluminum dust, combustible dust, Metal dust with flying sparks during grinding processes



DUSTOMAT HYDRO ATEX



Extraction arm at the grinding workplace

Wet separator  
DUSTOMAT HYDRO ATEX

1 x Extraction arm ATEX

Pipe system with butterfly valves

## References

### August Mink GmbH & Co. KG

Fiber and brush technology  
Extraction of fiber dust in production



High vacuum unit  
WHISPERSOG  
Extraction fan RG

### Infraserv Logistics

Logistic  
Workplace concept for pigment dust produced during filling work



2 x Compact dust extractors  
MOBEX P  
4 x Downdraft tables A-Serie  
4 x Extraction cabins  
2 x Extraction arms



## References

### Dr.-Ing. Ulrich Esterer GmbH & Co. Fahrzeugaufbauten und Anlagen KG – Helsa

Vehicle and mechanical engineering



Extraction at the workplace



FILTOWER in the production hall

3 × FILTOWER ecotemp  
5 × mobile Welding fume filters  
SRF K-15

### Hoffmann GmbH Qualitätswerkzeuge – Munich

Toolmaking



DUSTOMAT 24 –  
Extraction in robot cabin



DUSTOMAT 24  
with suction arms in showroom

2 × DUSTOMAT 24 ATEX  
Four extraction arms with hoods  
Pipe system

## Giesselmann – Bad Oeynhausen

Metalworking industry



Extraction at the workplace



MOBEX F-60 in the production hall

MOBEX F-60  
with spark pre-separator  
(4,500 m<sup>3</sup>/h at 3,400 Pa)

DUSTOMAT 4-10  
with cyclone water pre-separator  
(2,000 m<sup>3</sup>/h at 2,600 Pa)

Three extraction arms with  
hoods for welding fumes

Piping system

## FAIST Anlagenbau GmbH – Krumbach (Schwaben), Germany

System design

Hall ventilation system for welding fumes (ESTA Push Pull mixing ventilation)



Production hall with 24 welding workplaces



DUSTMAC Filtration unit with Extraction fan  
and Supply air fan

Filtration unit DUSTMAC F-567

Extraction fan 75 kW  
(45.000 m<sup>3</sup>/h bei 3.800 Pa)

Supply air fan 11 kW  
(13.500 m<sup>3</sup>/h bei 1.500 Pa)

Control unit  
with frequency converter

Pipe system with return air grille

## References

### Daimler Research Centre, Ulm

Research and Development (Automotive Industry)

Direct extraction of dust and shavings in model building applications and from different machines



Research centre, Ulm Germany



Extraction system with custom paint finish positioned outside

High vacuum extraction system with a 13 kW side channel blower and cyclonic filter FZ-1500 for general clean-up purposes and for direct extraction from different machines

Medium pressure system with 7.5 kW fan unit and cyclonic filter FZ-5000 for direct extraction of dust and shavings in model building

### Laser technology Kilgenstein

Metalworking

Hall ventilation systems for resulting particulate  
Welding fume wet separator for extracting aluminum dust



Two filter towers ensure clean air in the welding shop



Wet separators are installed on the four grinding booths to safely separate the partially explosive dust

2 x Filter tower FILTEROWER

4 x Wet separators NA K-7000

## References

### BBS – Schiltach

Automobilzulieferindustrie

Direktabsaugung an Schleif- und Bürstmaschinen sowie Handarbeitsplätzen



Absaugsystem in separatem Raum



Produktionshalle

Filtereinheit DUSTMAC F-567 mit drei Filtermodulen

Mitteldruckventilator MDV 75 kW (46.000 m<sup>3</sup>/h bei 3.900 Pa)

Schaltschrank Komfort Frequenzumrichter

3 Staubsammelbehälter mit je 50 Litern

Verzinkte Längsnahtglattrohre

### PERI GmbH – Weißenhorn

Shuttering · Formwork · Engineering

Welding fumes are extracted from the air in the production hall with the extraction system attached to the roof. Hall extraction system for 23 welding workstations (ESTA upstream stratification ventilation).



Hall ventilation system on the roof of the production hall

DUSTMAC F-945 filter unit

ATEX design

Two medium-pressure fans MDV-45 kW (75.000 m<sup>3</sup>/h bei 3.500 Pa)

Heat recovery

Pipe system with return air grille

Discharge through screw conveyor

## References

### IVECO MAGIRUS – Ulm, Germany

Automotive Manufacturer

Extraction of plastic dust from glass fibre reinforced materials used in manufacturing automotive components



Downdraft table with wood lattice grate work surface and extraction arm



Extraction unit DUSTMAC-F-64

Filtration unit DUSTMAC F-64 (7.300 m<sup>3</sup>/h at 3.800 Pa)

Downdraft table A2080 with wood work surface

Pipe system and Extraction arm

### Robert Bosch – Stuttgart, Germany

Automotive Supplier

Residual dust extraction during the cleaning of the production line



Control unit with monitoring lamps



Cyclonic filter FZ-1003 with 100Litre collection container

Cyclonic filter FZ-1003 with fill level monitoring

Side channel blower TDP-22 kW (2,100 m<sup>3</sup>/h at 27,000 Pa)

Control unit Comfort

Pipe system

Vacuum accessories

Dust Extractors

High Vacuum Extraction Units

Welding Fume Filters

Oil Mist Separators

Carbon Filters/ Air Purifier

Downdraft Tables

Extraction Fans

Extraction Arms

Filter Towers

Central Extraction Systems

Pipe Systems

About us

Interesting Information

## References

### SAF – Wörth am Main

Auto Body Production

Extraction of welding fumes and grinding dust from nine workstations and two welding robots



Extraction at a robotic welding station



Modular filtration unit

Filtration unit DUSTMAC-XF 432

Medium pressure fan MDV-45 kW  
(22,000 m<sup>3</sup>/h at 2,800 Pa)

Pipe system  
Nine extraction arms,  
Total length of the pipe system:  
90 m

### Sunseeker – Rostock, Germany

Ship Building

Extraction of glass fibre reinforced plastic dust, in the ship building industry



Dust extraction with an application specific pipe system



Filtration unit with explosion protection

Cyclonic filter FZ-5003

Side channel blower with  
Housing TDP-18.5  
(2,100 m<sup>3</sup>/h at 15,000 Pa)

Control cabinet Comfort

Pipe system with 100 flapper valves

Explosion protection

## References

### SAF-Holland GmbH

Vehicle construction

Welding fume extraction at manual workstations and robotic systems



DUSTMAC filter units



Acoustic-protection booth

Filter unit DUSTMAC-F 567  
2 x WELDEX F-150

Medium-pressure fan MDV-75 kW  
2 x medium-pressure fan  
MDV-15 kW

15 hoods  
at robotic workstations  
30 extraction arms  
at welding stations

### Groß Rotorblattfertigung GmbH

Wind energy sector

Extraction of GRP /CFRP dust created during the sanding of rotor blades



Mobile sanding station



DUSTMAC filter unit on sanding station

Filter unit DUSTMAC-F 144  
with police filter H 13

Medium-pressure fan MDV 15 kW  
ex-model in device group II, zone  
22 (non-conductive dust), category  
3D, temperature class T3, added  
to filter unit in accordance with  
explosion-protection directive  
94/9/EG (Atex)

50m mobile sanding station,  
soundproof, in torsion-resistant  
design with static proof

Dust-free removal  
with PVC bag

## References

### Additional References



Schwenk, Ulm, Germany



Braas, Altheim, Germany



Uhlmann, Laupheim, Germany



Thyssen Krupp Nirosta, Düsseldorf, Germany



OWB, Kisslegg, Germany



Sofragraf, Saint Ame, France

**Schwenk – Ulm**  
Cement Industry

**Braas – Altheim**  
Tile Manufacturing Plant

**Uhlmann – Laupheim**  
Packaging Systems

**Thyssen Krupp Nirosta – Düsseldorf**  
Metal Production Plant

**OWB – Kisslegg**  
Metalworking Industry

**Sofragraf – Saint Ame – Frankreich**  
Metalworking Industry

**ZI-Jena, Jena**  
Metalworking Industry

**Solidschuhwerk – Tuttlingen**  
**HAIX – Mainburg**  
**GABOR – Rosenheim**  
Shoe Industry

**Wacker Siltronic – Burghausen**  
Chemical and Semiconductor Industry

**EADS Deutschland – Augsburg**  
Aerospace Industry

**Liebherr-Aerospace – Lindenberg**  
Aerospace Industry

**Wieland Werke – Ulm**  
Metalworking Industry

**H. C. Starck – Hermesdorf**  
Metalworking Industry

**Daimler – Bremen**  
Automotive Industry

**Lamilux – Rehau**  
Plastics Industry



---

Spiral Seam Pipes

---

Steel pipes

---

Longitudinally welded pipes

---



### ***Application Range***

- » Agricultural Businesses
- » Aircraft Industry
- » Automotive Repair Shops
- » Automotive Supplier Industry
- » Construction Industry
- » Engine Manufacturing Plants
- » Electronics Industry
- » File Shredding
- » Food Processing Industry
- » Machine Building Industry
- » Metalworking Industry
- » Mills
- » Paper Industry
- » Pharmaceutical Industry
- » Precision Mechanical Industry
- » Printing Industry
- » Plastics Processing Plants
- » Recycling and Waste Processing Facilities
- » Research and Development
- » Ship Building Industry
- » Shoe Manufacturing Plants
- » Tobacco Industry
- » Vehicle and Auto Body Plants
- » Welding Plants

Dust Extractors

High Vacuum  
Extraction Units

Welding Fume  
Filters

Oil Mist  
Separators

Carbon Filters/  
Air Purifier

Downdraft  
Tables

Extraction Fans

Extraction Arms

Filter Towers

Central Extraction  
Systems

**Pipe Systems**

About us

Interesting  
Information

## Introduction and Product Overview

### Introduction

Even the best engineered extraction system is of little use if the design of the pipe system is not optimised. We use only high quality parts and materials for our pipe systems. In addition, our engineers calculate a ventilation technologically ideal design of the pipe system to ensure the best possible extraction performance of our equipment.

This type of care and thoroughness forms the basis of the “professional dust extraction” that customers expect from company ESTA.

For medium-pressure applications, ESTA offers a comprehensive selection of spiral seam ducts and moulded parts.



Extract air pipe with deflector hood

Steel pipes are used in high-vacuum extraction systems. Here also, ESTA offers all the pipes and moulded parts required for a complete solution to your system needs.



## Spiral Seam Pipes

Pipeline systems are connected to the dust or smoke source for optimal flow to the extraction system. ESTA has a comprehensive selection of spiral seam ducts whose robust, premium workmanship and flexibility make them excellent for your specific requirements.

Correct design is important to achieving maximum suction, because a tight network of pipelines ensures an economical system.

This is why all ESTA moulded parts have a double-lipped seal. ESTA also has the connectors and fasteners you need.



**ESTA PLUS**

### Application Range

- » Pipe system in the medium pressure range
- » Suction or pressure side

### Features

- » Galvanised sheet metal according to DIN \*) standard 24145
- » Standard length up to 3.0m
- » Ø 71 mm – 450 mm in stock \*\*)
- » Sheet metal thickness from 0.4 mm to 1.2 mm depending on pipe diameters

### Your Benefits

- » Extensive range of parts
- » Ventilation technologically optimised
- » Heavy duty workmanship
- » Easy installation

\*) DIN = German Industry Standard  
 \*\*) Larger diameters are available on short notice

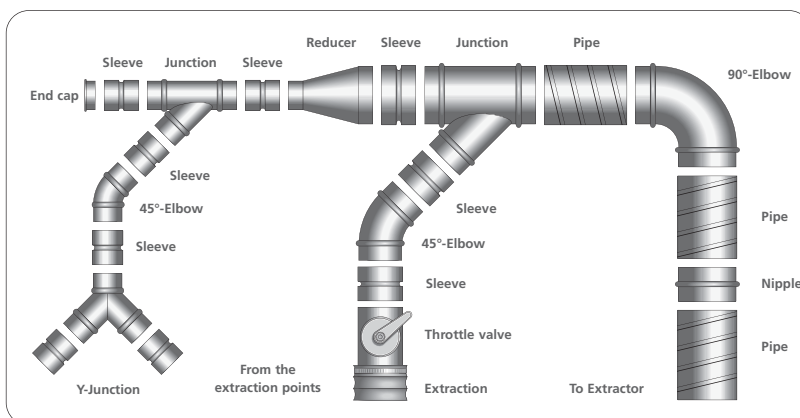

Dust Extractors

High Vacuum Extraction Units

Welding Fume Filters

Oil Mist Separators

Carbon Filters / Air Purifier

Downdraft Tables

Extraction Fans

Extraction Arms

Filter Towers

Central Extraction Systems

Pipe Systems

About us

Interesting Information

## Longitudinally welded pipes

As an alternative to the classic spiral seam tube, there is the longitudinally welded tube.

The main difference is the processing and joining of the individual shaped and pipe parts.

The spiral seam tube consists of a sheet metal strip coiled at an angle using a seam connection. Thus it forms a straight or bent pipe over the edges.

The longitudinally welded tube, on the other hand, is already produced as a welded tube. First, a hollow body is produced by bending or rolling sheet metal, which is then welded at the joints. Tubes up to 1,400 mm in diameter can be longitudinally welded, larger tubes are welded as winding tubes spirally welded, and large tubes are bent from heavy plates and welded in pieces.

By a simple connection with a clamp or clamping ring, the assembly (and disassembly for maintenance purposes) of the individual elements is very simple.



**ESTA**PLUS

### Area of use

- » Oil vapour
- » Abrasive media

### Features

- » From DN80 to DN 1400mm diameter
- » Material thickness from 0.6- 3mm
- » Galvanised, coated sheet metal or stainless steel possible
- » No sources of interference within the pipes
- » Increased resistance at same material thickness

### Benefits for you

- » High quality
- » Longevity due to low wear
- » Quick and easy installation

## Steel Pipes

In contrast to spiral seam ducts, steel pipes are used for extraction systems in the high vacuum range. Whether moulded parts, gate valves or flap valves, ESTA offers a diverse range of products for custom-rolled steel pipes.

The steel pipe components are precisely adapted to one another to make air leaks almost impossible. Both their robust workmanship and their optimal flow characteristics get maximum performance from your extraction system.



Pipe system



**ESTAPLUS**

### Application Range

- » Pipe system in the high pressure range
- » Suction or pressure side

### Features

- » Standard length up to 6.0 m
- » Outside diameters Ø 50 up to 159 mm available from stock
- » Patented pipe connector for potential equalization

### Your Benefits

- » Extensive range of parts
- » Ventilation technologically optimised
- » Heavy duty workmanship
- » Easy installation

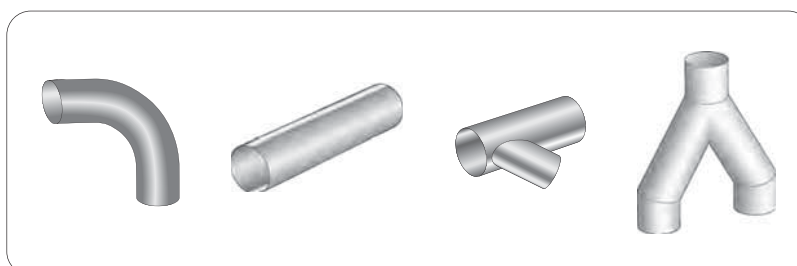
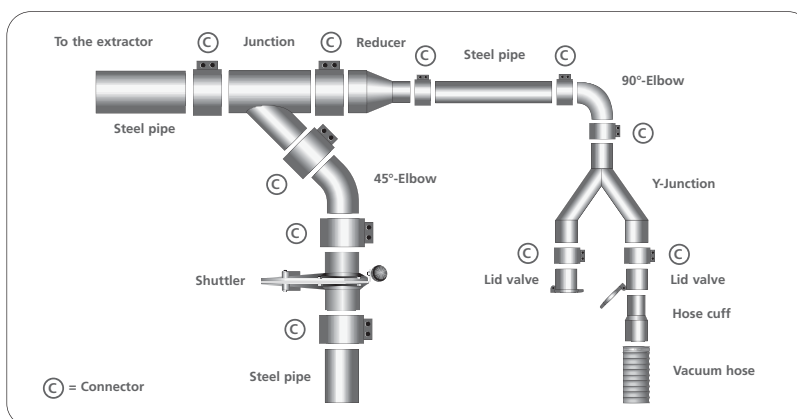

Steel pipes

Dust Extractors

High Vacuum  
Extraction Units

Welding Fume  
Filters

Oil Mist  
Separators

Carbon Filters/  
Air Purifier

Downdraft  
Tables

Extraction Fans

Extraction Arms

Filter Towers

Central Extraction  
Systems

Pipe Systems

About us

Interesting  
Information

## What sets us apart



### TECHNOLOGY PIONEER

Our passion is smart extraction technology that meets all your needs. Through permanent monitoring of the system parameters, the ESTA EasyControl control system developed by us allows optimal operation and, for example, predictive maintenance.



### HIGHEST QUALITY

We manufacture and test our extraction devices and filter systems subject to the strictest quality criteria at our headquarters in Senden (Bavaria). All our products are certified according to ISO 9001, so we can continuously guarantee you the highest quality.



### 50 YEARS OF EXPERTISE

With over 50 years of experience and over 500,000 installations and extraction systems worldwide, ESTA is your competent partner for clean air at the workplace. We are one of the leading manufacturers of extraction technology thanks to our wide range of standard equipment, but also our tailor-made solutions.



### RESPONSIBILITY (CSR)

We have made sustainable business, namely, the right balance of economy, ecology and social issues, our primary task. That's why, for example, we invest continuously in the development of resource-efficient products and are involved in numerous environmental initiatives.



### AFTER-SALES-SERVICE

The ESTA service team reliably ensures that your extraction system delivers consistently optimal results. We guarantee this through our comprehensive after-sale service, such as long term support, a competent maintenance service and an extensive stock of spare parts.



### COMPETENT CONSULTING & PLANNING

In addition to comprehensive professional advice, a design that is tailored precisely to your individual requirements is important. Our engineers use state-of-the-art software to produce detailed 3D drawings that are exactly tailored to your application.

## The benefit to you

Our high quality standards are realized through clearly structured work processes and the continuous development of process orientations. This enables us to meet the requirements and needs of our customers at all times. ESTA stands for innovative spirit, striving for quality and responsibility towards employees, society and the environment. Our commitment is reflected in numerous awards and certifications.

### Awards, Certificates and Memberships

#### Products and production

- » Certified quality management system according to DIN EN ISO 9001:2015
- » Certificate Production Site Inspection 2020 – Industrial Vacuum Cleaners and Dust Collectors
- » Certified environmental management system according to ISO 14001:2015

#### Membership

- » Blue Competence – German Engineering Federation (VDMA)
- » Purchasing Office Deutscher Eisenhändler GmbH (E/D/E)
- » Plattform Environmental Technology e.V.
- » Energy Efficiency Network Initiative
- » DVS – German Association for Welding and Allied Processes e.V.
- » Cluster ClustAir Bw – Competence Atlas



- Dust Extractors
- High Vacuum Extraction Units
- Welding Fume Filters
- Oil Mist Separators
- Carbon Filters / Air Purifier
- Downdraft Tables
- Extraction Fans
- Extraction Arms
- Filter Towers
- Central Extraction Systems
- Pipe Systems
- About us
- Interesting Information

## Human Resources / Personnel

- » Certificate of nomination for the SME award for social responsibility in Baden-Württemberg 2023 – Caritas and the Ministry of Finance and Economics of Baden-Württemberg
- » CSR Award of the Federal Government 2017
- » Member of the Initiative Fair Company 2016
- » Winner of the Ace of Training 2012 – Young German Business Promotion Award
- » Winner of the MAX-Award – “Ausbildungsbetrieb 2010” (Training company 2010) in the district of Neu-Ulm
- » Honorary prize for prevention services in health and safety at work 2010
- » Education partnership with WiSS (Wirtschaftsschule Senden)

## Cooperation partners

- » Partner in the “Donau-Iller” sheltered workshop
- » IPRI – International Performance Research Institute
- » Karlsruher Institute for Technologie (KIT)
- » The Fraunhofer Institute for Manufacturing Engineering and Automation IPA
- » Chamber of Industry and Commerce (IHK)
- » German Chamber of Commerce Abroad (AHK)
- » Mosbach Cooperative State University / Heidenheim / Ravensburg
- » University of Ulm
- » University of Neu-Ulm (HNU)
- » University of Stuttgart
- » Steinbeis Institute
- » Wirtschaftsschule Senden





## Energy-efficient extraction technology

### Powerful, energy-efficient and economical

ESTA extraction systems combine outstanding extraction and filtration performance with the highest degree of efficiency, with minimal operating costs. This is ensured by the new ESTA control system in combination with sophisticated sensor technology, as well as the use of frequency inverters.

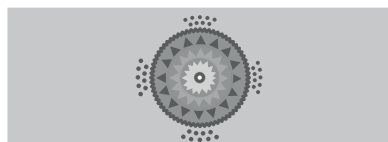

#### Effective and resource-saving filter technology

ESTA extraction systems have permanent filter cartridges (degree of separation up to 99.9%). Special pre-separation systems developed by ESTA and for which a patent is pending, as well as the effective jet-pulse filter cleaning system, significantly extend the service life of the filters, which ensures low operating costs.



#### Powerful and economical drive technology

Through a combination of efficiency class IE 3 drive motors with frequency inverters, the power of the motors can be controlled as required and is thus always within the optimum working range. The above-average efficiency of the fans also ensures maximum extraction power.

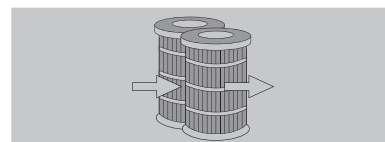

#### Energy-efficient airflow

The raw gas flow in the filter chamber guarantees an even impact on the filter elements and low pressure loss. A low pressure loss clean air duct ensures low performance losses and low flow noise. Large-area air outlets enable low-draft air recirculation into the work area.

### Functional overview of the ESTA control system

- » Intuitive operation thanks to convenient touch display
- » Display of the most important operating parameters (e. g. status, operating hours, maintenance)
- » Remote maintenance
- » Timer
- » Residual dust & filter breakage monitoring



### More efficiency with intelligent control

The ESTA control system ensures energy-efficient operation of the unit. By measuring the current volume flow and the fully automatic adjustment of the extraction power to the respective operating parameters, there is an energy saving of up to 50%

compared to a conventional differential pressure Control system.

The adjustable air volume flow also extends the filter service life, since the dust particles do not constantly impact the filter material at maximum speed, thus protecting the fabric.

## Smart extraction technology

### Intelligently networked into the future

ESTA extraction systems in the industrial 4.0 version have integrated network and protocol functions, which can be seamlessly integrated into a 4.0 environment. This implementation is done via any data connection such as LAN, WLAN or LTE. Users can retrieve and monitor the most important operating data such as air volume flow, operating hours or filter status at any location – even via tablet and smartphone.

This way, companies proactively avoid machine failures that could lead to a standstill of the entire

production chain. The measurement data obtained also shortens the troubleshooting time for service technicians. The procurement of spare parts can also be planned more efficiently.

The result: operating costs are considerably reduced. In addition, all measurement and operating data is permanently logged.

We offer predictive maintenance with our partner Advanced Industry Analytics. Please contact us for more information: [esta@industry-analytics.com](mailto:esta@industry-analytics.com).

### Your benefit

- » Simple coupling of the extraction system to company-specific network infrastructure via LAN/WLAN
- » Remote access and monitoring of all operating data is possible worldwide, even by the user himself
- » Reduction of failure risk through permanent logging and monitoring of operating parameters
- » Reduction of maintenance and service costs through remote monitoring and maintenance



## Quality from our own production

Our core competences lie in the application-specific design, construction and manufacture of extraction systems with the associated filter technology. We have been producing in Germany since our foundation in 1972 and will continue to do so in the future. This enables us to continuously optimize our quality production, because an excellent performance of our products at market-driven prices is our top priority.

Our certified quality management system guarantees compliance with all safety, quality, and environmental aspects within our value chain. In addition, we have also improved the Lean Production thoughts, which is deeply anchored in the company.

### Our quality guarantors:

- » Quality Management System DIN EN ISO 9001:2015
- » Supplier audits
- » Goods receipt and goods issue inspection
- » Quality gates
- » Subassembly production
- » 100 % Final inspection
- » Own assembly teams
- » On-site device acceptance incl. ventilation measurements
- » External tests by IFA and TÜV (GS)
- » CE certification
- » Use of Lean, Kaizen and KVP
- » High degree of standardization, e.g. through sales configurator
- » In-house switch cabinet construction

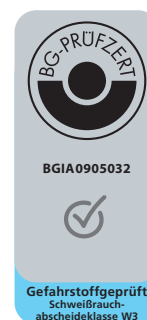

- Dust Extractors
- High Vacuum Extraction Units
- Welding Fume Filters
- Oil Mist Separators
- Carbon Filters / Air Purifier
- Downdraft Tables
- Extraction Fans
- Extraction Arms
- Filter Towers
- Central Extraction Systems
- Pipe Systems
- About us
- Interesting Information

## Innovation & Know-how

In our innovation department we deal with the digital technologies of tomorrow and the networking of different systems. In addition to developing new products, we are constantly working on optimizing existing devices to make them even more efficient and fit for the digital world.

We benefit from our over 50 years of experience and competence in extraction and filter technology, in conjunction with our close proximity to our customers. ESTA works also closely together with numerous associations, initiatives and networks, such as the KIT Fraunhofer – because together we achieve more.

In our pilot plant we carry out a large number of tests in order to validate ideas in practice. In the last 5 years, there has been a 15-fold increase in the number of patent applications to date and an increase of 80 % in the number of inventor applications. This is due in part to the use of state-of-the-art 3D printing technology.



## Clean the air – save the ocean



### Our oceans are vital providers of oxygen

Every other breath that we take is obtained thanks to the oxygen produced by the planet's seas. In total, they produce 70% of all of the oxygen that we breathe.<sup>1</sup> They influence our climate, they provide us with nutrients, raw materials and energy. And they help to support trade worldwide.

Reefs, seagrass beds and salt marshes, together with kelp forests, fulfil a crucial carbon-sink role, making our oceans the largest producers of oxygen worldwide.

### Buy ESTA wet separators and make an active contribution to marine conservation

Wet separators use water as a natural filtration medium, and ensure clean, healthy air to breathe at the workplace.

The campaign „Clean the air – save the ocean“ supports worldwide marine conservation projects with the aim of protecting our most important source of oxygen, the oceans, against the effects of climate change.

### How can we protect the seas?

Habitats, and the ranges of species which they contain, can be protected and preserved where marine conservation zones are set up. In the conservation zones, human operations such as fisheries or drilling for oil are prohibited or regulated. By this means, the seas are made more resistant to climate change.



<sup>1</sup> Source: [www.wwf.de/themen-projekte/meere-kuesten/klima-und-meer](http://www.wwf.de/themen-projekte/meere-kuesten/klima-und-meer)

- Dust Extractors
- High Vacuum Extraction Units
- Welding Fume Filters
- Oil Mist Separators
- Carbon Filters/ Air Purifier
- Downdraft Tables
- Extraction Fans
- Extraction Arms
- Filter Towers
- Central Extraction Systems
- Pipe Systems
- About us
- Interesting Information

## Clean the air – plant a tree

### Trees as climate savers

Trees are real climate protectors: they absorb CO<sub>2</sub> from the air and incorporate the carbon of the greenhouse gas into their biomass. In the course of its lifetime, a tree can compensate for approx. 1,000 kg\* of CO<sub>2</sub>.

But trees can do more than just clean the air and produce oxygen. Forests improve soil properties and create important habitats for many different animal and plant species. They also serve as places of retreat and recreation for us humans.



CLEAN THE AIR  
PLANT A TREE



### Filter towers that plant trees

With the campaign “Clean the air – plant a tree” we have the foundation stone for the ESTA corporate forest. We gave our customers a tree sponsorship when they bought a filter tower and gave them that way the chance to make a personal contribution to climate protection.

The trees that have been planted are now deeply rooted in the ground and will ensure clean air to breathe in the future.

### Corporate forest as a model for the future

The ESTA Forest covers an area of just under one hectare and is located only 20 kilometres from the company headquarters in Senden, near Erbach, a small town in the Alb-Donau district of Baden-Württemberg.

The reforestation project, in which ESTA trainees are also involved, is accompanied by the owner of the large forest, Freiherr Constantin von Ulm-Erbach, as forest godfather and has a model character for him.

Coniferous and deciduous trees, such as Douglas fir and black walnut, are planted, which are considered to be particularly climate-resistant.

If they are able to withstand the increasing extremes of the weather such as droughts, heat waves, heavy rain, long cold phases and hurricanes, conclusions can be drawn for further afforestation.

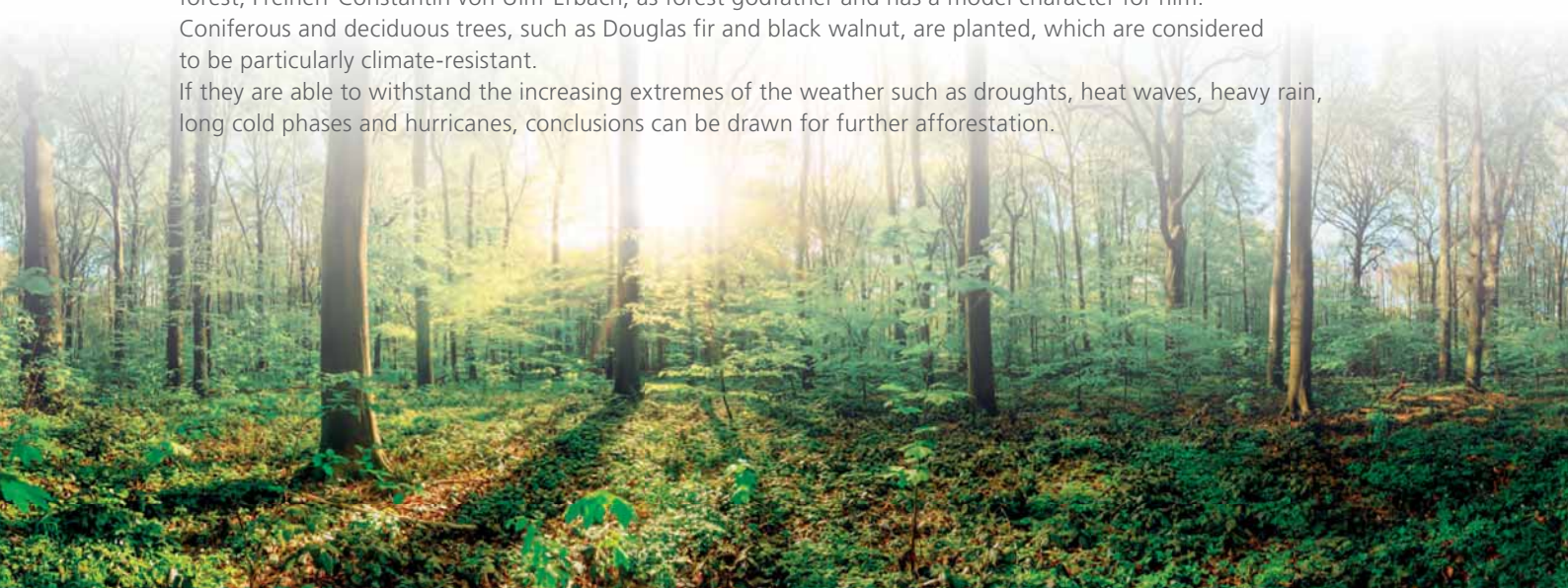

\* per year, values vary according to tree species and size | Source: [www.plant-for-the-planet.org](http://www.plant-for-the-planet.org)

## Original Equipment Manufacturer/OEM

For more than 50 years ESTA has been one of the leading companies in the field of extraction and filter technology. Based out of Senden and Ulm, we manufacture a wide range of innovative products and customized solutions for industry and trade – for a wide variety of industries and applications.

We use our decades of experience and expertise to offer our partners, as original equipment manufacturers, the best products and services in the industry, so that they can benefit from satisfied customers.

### Our services

- » Devices in customer-specific paintwork and lettering
- » Personal support and technical advice from trained specialists
- » Sales support throughout the entire OEM product launch process in the target market
- » Country-specific solutions
- » Joint product developments
- » Product training in the ESTA Academy
- » Marketing support for online and offline media
- » Country-specific solutions
- » Various special solutions (e.g. mounting options)
- » Reliable and fast spare parts supply
- » Online shop for accessories



Dust Extractors

High Vacuum  
Extraction Units

Welding Fume  
Filters

Oil Mist  
Separators

Carbon Filters/  
Air Purifier

Downdraft  
Tables

Extraction Fans

Extraction Arms

Filter Towers

Central Extraction  
Systems

Pipe Systems

About us

Interesting  
Information

## Guidelines and regulations

### What are the important guidelines for extraction systems?

A declaration of conformity must be drawn up in order to place extraction systems on the European market: By affixing the CE mark to the product, the manufacturer confirms that his extraction systems comply with European standards.

An assessment is carried out in advance to identify the relevant guidelines and standards under which the extraction system falls. Normally, the Machinery Directive, the Low Voltage Directive and the Electromagnetic Compatibility Directive apply. Depending on the customer's application, the ATEX product directive can also be applied.

### Current directives, standards and regulations

The current status of the guidelines in the field of extraction technology is:

- » Machinery Directive: 2006/42/EC
- » Low Voltage Directive: 2014/35/EU
- » Electromagnetic Compatibility Directive: 2014/30/EU
- » ATEX Product Directive: 2014/34/EU Hazardous Substances Ordinance

In addition, the manufacturer refers in the declaration of conformity to the harmonized standards and technical rules or DGUV regulations that were consulted by the designers during the project planning of the extraction system.

### Some examples of current regulations for extraction systems:

- » DGUV Regulation 109-001: Grinding, brushing and polishing of aluminium – Prevention of dust fires and dust explosions (formerly BGR 109)
- » DGUV Regel 109-002: Workplace ventilation – Ventilation measures (formerly BGR 121)
- » DGUV Rule 209-044: Wood dust (formerly BGR 739-1)
- » DGUV Rule 209-077: Welding smoke – suitable ventilation measures
- » DGUV Information 209-073: Workplace ventilation – Decision-making aids for operational practice
- » DGUV Information 209-078: Buying extraction systems – the right way!
- » TRGS 528: Technical welding work
- » TRGS 560: Air recirculation when handling carcinogenic hazardous substances

### Guidelines at ESTA Absaugtechnik

ESTA extraction systems are tested according to the CE guidelines. They comply with the European specifications, standards and directives for extraction systems and are therefore provided with a CE mark.

We will be happy to advise and support you on the subject of CE and conformity declarations with regard to extraction systems.

### Please contact us!

**+49 7307 3 40 96 80 - 0**  
**export@esta.com**



## What You Should Know About Dust

### What is dust?

Dust consists of visible and invisible, floating and fallen particles of solid material. The larger the particles, the less they float (depending on type and properties). If the particles are very small (such as with metal dusts), the dust stays in the air continuously and does not fall.

In assessing dust particles' toxicity, both the size and the chemical composition play a decisive role.

### Grain sizes in dust

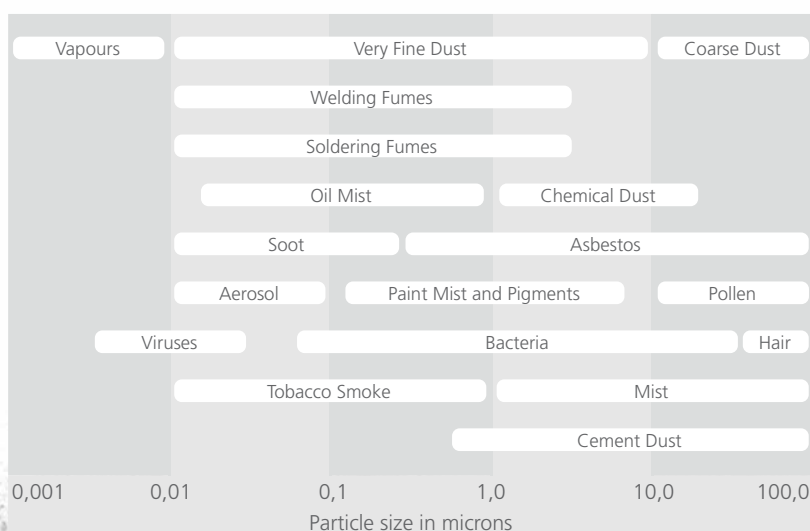

### Limit values

The OEL (Occupational Exposure Limit) is defined as the maximum concentration of a contaminant in workplace air.

On page 121, you can find an overview of the most common types of dust along with their application categories (test certificates).

### Contact with dust can be a source of illness if

“ the concentration is very high  
 “ the dust particles are small enough to penetrate through the trachea and bronchi deep into the lungs (alveoli)

“ particles' shape (such as fibres) promotes penetration  
 “ the dust contains poisonous substances

### Occupational limit value table

Suitable for dry, health hazardous, non-flammable dust types Since 01.01.2005	Applicable dust classes per DIN DIN EN 60335-2-69 Anh. AA	
	Dust Classification	Max. Transmittance
With occupational limit value > 1 mg/m <sup>3</sup>	At least <b>L</b> (M, H)	< 1 %
With occupational limit value ≥ 0,1 mg/m <sup>3</sup>	At least <b>M</b> (H)	< 0,1 %
With occupational limit value < 0,1 mg/m <sup>3</sup>	<b>H</b>	< 0,005 %
Carcinogenic substances (GefStoffV § 11, TRGS 905 bzw. TRGS 906 – Regulation for Hazardous Substances)	<b>H</b>	< 0,005 %
Asbestos (TRGS 519 - Regulation for Hazardous Substances)	<b>H</b> + suitable for use in accordance with TRGS 519	< 0,005 %
Also suitable for flammable dust types of all explosive dust classifications (with the exception of dust types with extremely low minimum ignition energy (MIE) ME < 1mJ)	At least <b>L</b> with <b>Zone 22</b> (in addition)	

Further information at <http://www.dguv.de/medien/ifa/de/prg/staubklassen/staubkl.pdf>

### General dust limit value\*

Breathable dust fraction	10 mg/m <sup>3</sup>
Alveolar dust fraction	1,25 mg/m <sup>3</sup>

\* for materials with no special toxic characteristics

Dust Extractors

High Vacuum Extraction Units

Welding Fume Filters

Oil Mist Separators

Carbon Filters / Air Purifier

Downdraft Tables

Extraction Fans

Extraction Arms

Filter Towers

Central Extraction Systems

Pipe Systems

About us

Interesting Information

# Interesting information

## Excerpt from the Table of Dust Types

Dust Types	MEL-Values (mg/m <sup>3</sup> )	DC*
<b>Aluminium</b> (as metall)	<b>1,25</b> Date: 02/14	L
<b>Aluminum oxide</b>	<b>1,5</b> Date: 02/14	L
<b>Aluminum oxide smoke</b>	<b>1,25</b> Date: 02/14	L
<b>Barium (Ba)</b> Working with brass (copper and zinc) and diverse alloys (with silver, cadmium, chrome, beryllium, nickel), electrical industry	<b>0,5, E</b> Date: **	M
<b>Lead (Pb)</b> Casting of lead and its alloys, production of ammunition and lead storage batteries, welding and cutting of metals containing lead and colours with a torch or arc welding, steel cable production, wire drawing, diamond grinding, shooting range	<b>0,15, E</b> Date: 02/07	M
<b>Cadmium (Cd)</b> Cadmium plating of metals, steel alloys, production of welding rods, colour pigments, welding and etching of cadmium alloys, production of solar cells, plastics industry (Cd as stabilizer) carcinogenic	<b>0,16 µg/m<sup>3</sup>, A</b> <b>1,0 µg/m<sup>3</sup>, E</b>	H
<b>Chrome (Cr)</b> Corrosion resistant alloys (Ferrochrome), electrolytic chrome plating, production of chromate and bichromate for the textile industry, printing companies, tanneries, dyeing plants, photography, paint, chrome alloys, (arc welding) carcinogenic	<b>from 0,1 to 0,03, G</b> depending on the type of chrome and the processing method Date: 02/09	H
<b>Iron Oxide (FeO<sub>3</sub>)</b> Welding, Metalworking, in iron and ochre mines	<b>from 3 to 10,</b> depending on the task Date: 06/10	L
<b>Gypsum</b> Gypsum production	<b>6, F</b> Date: 06/10	L
<b>Graphite</b> (crystalline carbon) Fabrication of electrodes and heat resistant moulds	<b>1,25</b> Date: 02/14	L
<b>Wood</b> Woodworking industry, joineries, carpenter shops, parquet installers	<b>2 + 5, E</b> Date: **	M H
<b>Diatomite, calcined and diatomite smoke</b>	<b>0,3, A</b> Date: 06/10	M
<b>Diatomite, non-calcined</b>	<b>4, E</b> Date: 06/10	L
<b>Dust containing silicic acid (SiO<sub>2</sub>)</b> Quartz quarries, sandstone, fire stone, quartzite, slate, foundries with sand moulds, porcelain, sanitary and heat resistant ceramics, high temperature ovens, glass industry, sanding of sand stone, construction industry, production of silicon carbide	<b>0,15</b>  <b>4, F</b> if SiO <sub>2</sub> content is > 4% Date: 06/10	M L

Dust Types	MEL-Values (mg/m <sup>3</sup> )	DC*
<b>Cobalt (Co)</b> Special alloys, hardened metal industry, glass and ceramics industry (enamel), cobalt plating of metals, grinding of surgical prostheses, diamond grinding, carcinogenic	<b>0,5, E</b> Date: 05/08 Minimization requirements	H
<b>Copper (smoke)</b> Working with brass (copper and zinc) and diverse alloys (with silver, cadmium, chrome, beryllium, nickel), electrical industry	<b>In progress</b>	
<b>Manganese (Mn; smoke)</b> Iron-manganese-electrodes, metallurgy, dry batteries, colours for ceramic and glass (in the form of salt)	<b>0,02, A</b> <b>0,2, E</b>	H
<b>Flour</b>	<b>4</b> Date: **	L
<b>Nickel (Ni; Oxide)</b> Electrolytic nickel plating, batteries, coins and kitchen utensils, heat and corrosion resistant steel	<b>0,03, E</b> <b>0,006, A</b> Date: 02/09	H
<b>Quartz</b>	<b>0,05, A</b> Date: **	H
<b>Quicksilver compounds</b> carcinogenic	<b>0,02, E</b> Date: 06/10	H
<b>Grain dust</b> Agriculture, bakeries, mills, work in silos	<b>4, E</b> Date: **	L
<b>Silver</b>	<b>0,1, E</b> Date: 06/10	M
<b>Silver compounds, soluble</b>	<b>0,01, E</b> Date: 05/08	H
<b>Tobacco</b>	<b>0,5, G</b> Date: **	L
<b>Titan (Ti)</b> Titan(IV)oxide	<b>0,5, F</b> Date: 06/10	L
<b>Cement dust</b> Cement plants	<b>In Progress</b>	
<b>Zinc (Zn; Oxide)</b> Galvanizing, use of brass (copper and zinc), colours and colour pigments with zinc or zinc oxides	<b>2, E</b> <b>0,1, G</b> Date: **	L
<b>Pewter (Sn)</b> Organic and inorganic compounds pewter plating of metals, working with pewter alloys. Organic derivatives are used for the production of plastics and pesticides	<b>2, G</b> <b>0,1, G</b> Date: **	L H

\* = Dust Classification  
\*\* no limit currently specified  
F/G = Values referring to the breathable fraction

Further information and occupational exposure limit values can be found in the IFA Report 01/2018, List of Hazardous Substances 2018 and in the regulations TRGS 900 as well as under:

[www.esta.com/wissen](http://www.esta.com/wissen)

## Fire protection and ATEX

### For a safe workplace

Fire and explosion hazards exist in all industrial plants in which flammable and explosive dusts occur.

The terms „fire hazard“ and „explosion hazard“ are often used synonymously. Of course there are certain influences among each other, but during project planning both must be separated, because fire protection measures do not prevent an explosion – and vice versa.

**Therefore, we would like to explain the terms „fire“ and „explosion“ separately at this point.**



### Fire protection

A decisive indicator for the possible ignitability of a dust and the spread of a fire is the number of flames. This is classified as follows:

Type of reaction		BZ	Examples
No spread of a fire	No burning	1	Table salt
	Short burn-on and rapid extinction	2	Tartaric acid
	Local burning or smouldering with a minimum of spread	3	Lactose
Fire spread	Annealing without sparking (smouldering fire) or slow, flameless decomposition	4	Tobacco
	Propagation of open fire or burning under spark spraying	5	Sulphur
	Deflagration-like combustion or rapid flameless decomposition	6	Black powder

A determination of the burning number can be made via the EX-Gestis (<http://staubex.ifa.dguv.de>) or via a substance analysis, which we can carry out for you.

### We can offer the following deletion variants:

- » ABC powder extinguishing (D for metals, if applicable)
- » CO2 quenching
- » Argon deletion
- » Water extinguishing

ESTA has developed a three-stage security concept, which we coordinate individually with the customer. If the customer wishes to deviate from the concepts, we advise and project these wishes and point out the corresponding advantages and disadvantages in advance. You will find decision-making aids for a safety concept in the standards VDI 2263 Part 6 and VdS 3445, among others.

- Dust Extractors
- High Vacuum Extraction Units
- Welding Fume Filters
- Oil Mist Separators
- Carbon Filters / Air Purifier
- Downdraft Tables
- Extraction Fans
- Extraction Arms
- Filter Towers
- Central Extraction Systems
- Pipe Systems
- About us
- Interesting Information

# Interesting information

## Explosion protection

If one speaks of explosion protection, one meets the term ATEX with high probability.

**ATEX stands for ATmosphères Explosibles.**

Explosion protection is regulated by the ATEX directive, which is divided into the following categories

**ATEX-Product directive 2014/34/EU**

and the

**ATEX-Operational policy 1992/92/EG**

The term „explosion“ refers to a chemical reaction or physical process in which the temperature and pressure rise considerably in a very short time (a few milliseconds).

This results in a sudden volume expansion of gases and the release of large amounts of energy in a small space.

The sudden release of energy causes a pressure wave that expands in all directions with attenuation.

After a certain time, the pressure wave is overtaken by the flame front (deflagration).

The prerequisite for an explosion is the so-called “explosion triangle”:

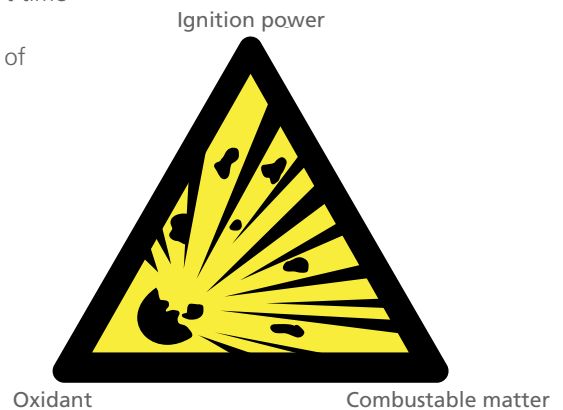

## ATEX extraction systems

There is always a risk of explosion in all extraction systems in which combustible dust occurs. Under certain conditions, an explosive mixture forms in these „Ex areas“ in conjunction with air. A small spark (e.g. due to static charging) is sufficient to cause a dust explosion.

In order for our extraction systems to be designed for explosion protection and ATEX extraction, certain parameters must be known.

These include, for example:

- » The minimum ignition energy (MIE)
- » Explosion limits (UEG/OEG)
- » Dust explosion class Kst value
- » Grain size





## ATEX zones

In addition, the extraction system is divided into zones. A distinction must be made between gases and dusts.

For gases:	
Zone 0	a place in which a dangerous explosive atmosphere consisting of a mixture of air and flammable substances in the form of gas, vapour or mist is <b>present continuously, for long periods of time or frequently</b>
Zone 1	is a place in which an explosive atmosphere consisting of a mixture of air and flammable substances in the form of gas, vapour or mist may <b>occasionally occur</b> in normal operation
Zone 2	is a place in which, during normal operation, a dangerous explosive atmosphere consisting of a mixture of air and flammable substances in the form of gas, vapour or mist is not likely to occur in normal operation but is unlikely to occur in <b>normal operation and is likely to persist for a short period only</b>
For dusts:	
Zone 20	a place in which a dangerous explosive atmosphere in the form of a cloud of combustible dust in air is <b>present continuously, for long periods of time or frequently</b>
Zone 21	is a place in which, during normal operation, an explosive atmosphere in the form of a cloud of combustible dust in air may <b>occasionally occur</b>
Zone 22	is a place in which, during normal operation, a dangerous explosive atmosphere in the form of a cloud of combustible dust in air is not likely to <b>occur or is likely to occur only infrequently and for a short period only</b>

## Explosion protection measures

- » Plant components electrically conductive throughout
- » Ignition hazard assessment
- » Explosion pressure or explosion pressure shock-resistant construction of apparatuses
- » Non-return valves
- » Flameless pressure relief
- » Explosion suppression systems
- » Preparation of an explosion protection document



## We provide our services in accordance with the following legal principles:

- » Ordinance on Industrial Safety and Health (BetrSichV)
- » Ordinance on Hazardous Substances (GefStoffV)
- » Directive 1999/92/EC
- » Directive 2014/34/EU
- » Technical Rules for Operational Safety (TRBS), e. g. TRBS 1201 Part 1
- » Technical Rules for Hazardous Substances (TRGS), e. g. TRGS 510 and TRGS 509

*Do not expose yourself and your environment unnecessarily to danger!  
Gain a head start through Safety – with ATEX compliant products from ESTA.*

*Our sales consultants will work with you to find the right solution.*

Please contact us!

**+49 7307 3 40 96 80 - 0 · export@esta.com**

- Dust Extractors
- High Vacuum Extraction Units
- Welding Fume Filters
- Oil Mist Separators
- Carbon Filters / Air Purifier
- Downdraft Tables
- Extraction Fans
- Extraction Arms
- Filter Towers
- Central Extraction Systems
- Pipe Systems
- About us
- Interesting Information

Notes

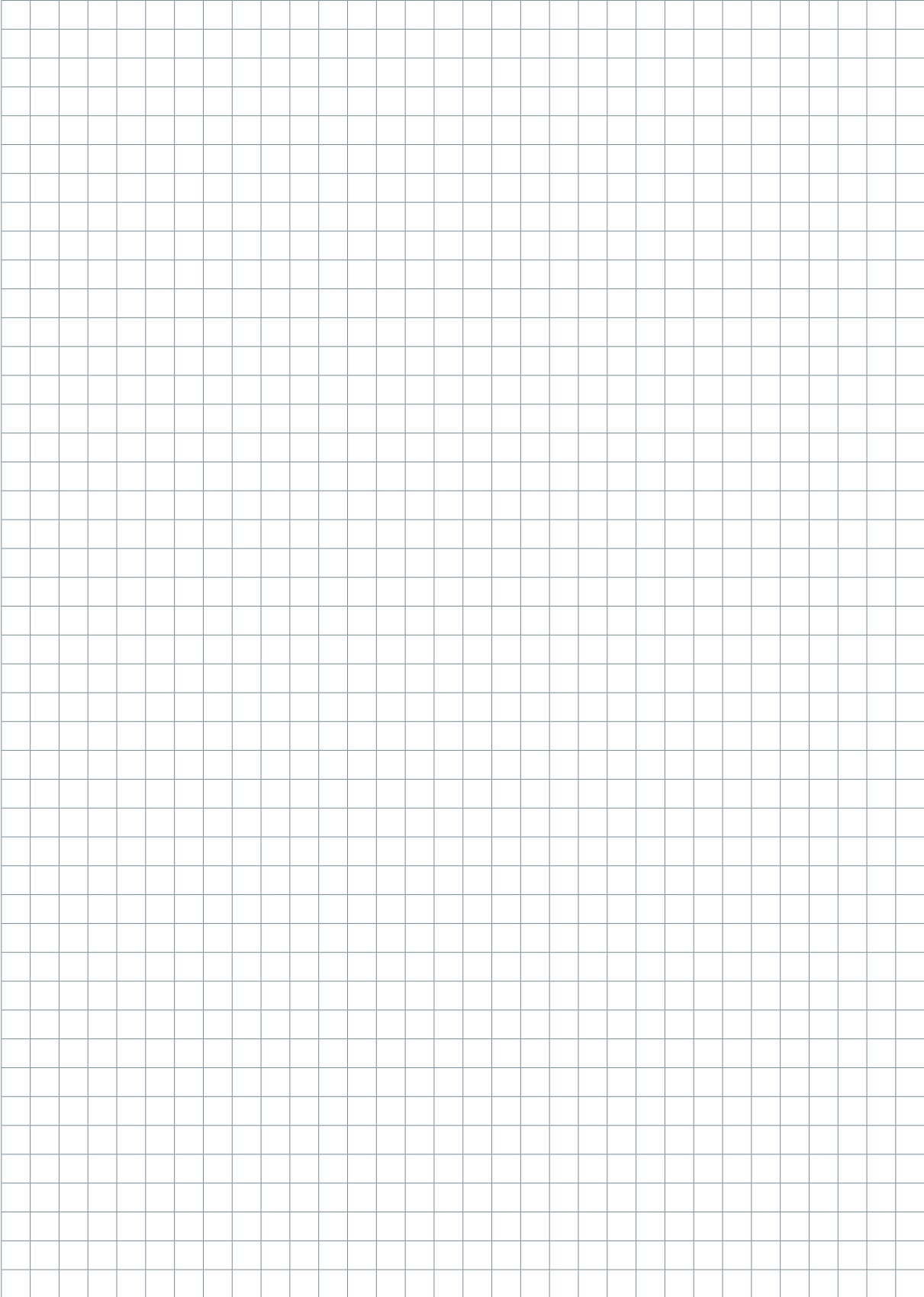

Information and communication are very important to us.  
Please request our information materials.

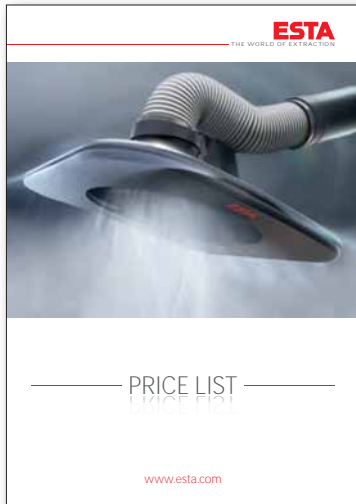

ESTA Price list



Image Brochure

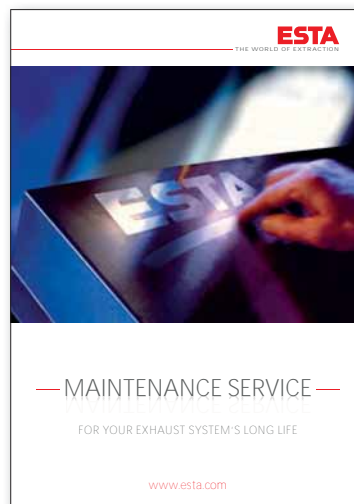

ESTA Maintenance Service

Request it now

**Phone +49 7307 3 40 96 80-0**

**Fax +49 7307 804-500**

**E-Mail [export@esta.com](mailto:export@esta.com)**

**[www.esta.com](http://www.esta.com)**



- » *Mobile Dust Extractors*
- » *Stationary Dust Extractors*
- » *High Vacuum Extraction Units*
- » *Welding Fume Filters*
- » *Air Purifier*
- » *Oil Mist Separators*
- » *Carbon Filters*
- » *Downdraft Tables*
- » *Extraction Fans*
- » *Extraction Arms*
- » *Hall Ventilation Systems*
- » *Central Extraction Systems*
- » *Pipe Systems*

#### ESTA Sales Companies

- » Poland
- » Slovakia
- » USA

#### ESTA Agents

- » Austria
- » Bulgaria
- » Canada
- » Croatia
- » Czech Republic
- » Denmark
- » Estonia
- » France
- » Hungary
- » Ireland
- » Israel
- » Lithuania
- » Mexico
- » Netherlands
- » Romania
- » Russia
- » Saudi Arabia
- » Singapore
- » Slovenia
- » Spain
- » Switzerland
- » Turkey
- » United Kingdom
- » United Arab Emirates

#### ESTA Apparatebau GmbH & Co. KG

Gotenstraße 2–6  
89250 Senden / GERMANY  
Phone +49 7307 3409680-0  
Fax +49 7307 804-500  
E-Mail [export@esta.com](mailto:export@esta.com)